

INSTALLER: LEAVE THIS MANUAL WITH THE APPLIANCE.
CONSUMER: RETAIN THIS MANUAL FOR FUTURE REFERENCE.



INSTALLATION AND OPERATING INSTRUCTIONS

CERTIFIED UNDER CANADIAN AND AMERICAN NATIONAL STANDARDS: CSA 2.33, ANSI Z21.88 FOR VENTED GAS FIREPLACE HEATERS.

CDI-30GN NATURAL GAS

CDI-30GP PROPANE

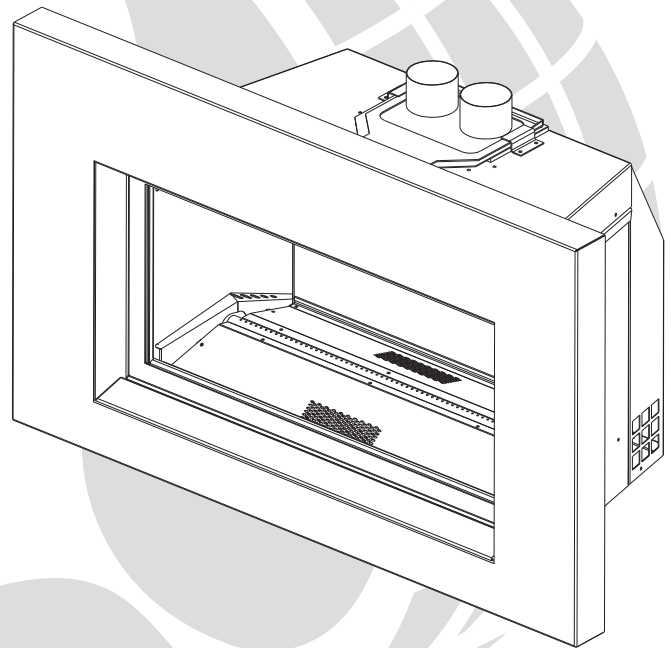

CERTIFIED FOR CANADA AND UNITED STATES USING ANSI/CSA METHODS.

SAFETY INFORMATION

WARNING

If the information in these instructions are not followed exactly, a fire or explosion may result causing property damage, personal injury or loss of life.

- Do not store or use gasoline or other flammable vapors and liquids in the vicinity of this or any other appliance.
- **WHAT TO DO IF YOU SMELL GAS:**
 - Do not try to light any appliance.
 - Do not touch any electrical switch; do not use any phone in your building.
 - Immediately call your gas supplier from a neighbour's phone. Follow the gas supplier's instructions.
 - If you cannot reach your gas supplier, call the fire department.
- Installation and service must be performed by a qualified installer, service agency or the supplier.



APPLY SERIAL NUMBER LABEL FROM CARTON



Serial No. XXXXXX000000
MODEL NO.

Wolf Steel Ltd., 24 Napoleon Rd., Barrie, ON, L4M 4Y8 Canada /
103 Miller Drive, Crittenden, Kentucky, USA, 41030
Phone (705)721-1212 • Fax (705)722-6031 • www.continentalfireplaces.com • ask@continentalfire.on.ca

TABLE OF CONTENTS

1.0	INSTALLATION OVERVIEW	3
2.0	INTRODUCTION	4
	2.1 DIMENSIONS	5
	2.2 GENERAL INSTRUCTIONS	5
	2.3 GENERAL INFORMATION	6
	2.4 RATING PLATE INFORMATION	7
	2.5 CARE OF GLASS	7
3.0	INSTALLATION	8
	3.1 INSERT LEVELLING	8
	3.2 CHIMNEY CONNECTION	9
	3.3 GAS INSTALLATION	10
	3.4 OPTIONAL WALL SWITCH / THERMOSTAT	10
4.0	FRAMING	11
	4.1 MINIMUM MANTEL CLEARANCES	11
5.0	FINISHING	12
	5.1 4 SIDED SURROUND	12
	5.2 DOOR REMOVAL AND INSTALLATION	12
	5.3 DOOR GLASS REPLACEMENT	13
	5.4 MEDIA TRAY INSTALLATION	14
	5.5 MEDIA INSTALLATION	14
	5.6 LAMP REPLACEMENT	15
	5.7 LAMP ASSEMBLY REPLACEMENT	15
	5.8 LOGO PLACEMENT	15
6.0	REPLACEMENT BLOWER INSTALLATION	16
7.0	OPERATION	17
	7.1 OPERATING AND LIGHTING INSTRUCTIONS	17
	7.2 ANTI CONDENSATION SWITCH	18
8.0	WIRING DIAGRAM	18
	8.1 NIGHT LIGHT™ WIRING DIAGRAM	19
9.0	ADJUSTMENTS	20
	9.1 PILOT BURNER ADJUSTMENT	20
	9.2 VENTURI ADJUSTMENT	20
	9.3 FLAME ADJUSTMENT	21
	9.4 FLAME CHARACTERISTICS	21
10.0	MAINTENANCE	21
11.0	REPLACEMENTS	22
12.0	TROUBLE SHOOTING	24
13.0	WARRANTY	27
14.0	SERVICE HISTORY	28

NOTE: Changes, other than editorial, are denoted by a vertical line in the margin.

1.0 INSTALLATION OVERVIEW

FIGURE 1.0

Door, see "FINISHING - DOOR
REMOVAL AND INSTALLATION"
section.

Venting, see "INSTALLATION - CHIMNEY
CONNECTION" section.

Surround, see "FINISHING - 4 SIDED
SURROUND INSTALLATION" section.

Glass, see "FINISHING - GLASS
BURNER INSTALLATION" section.

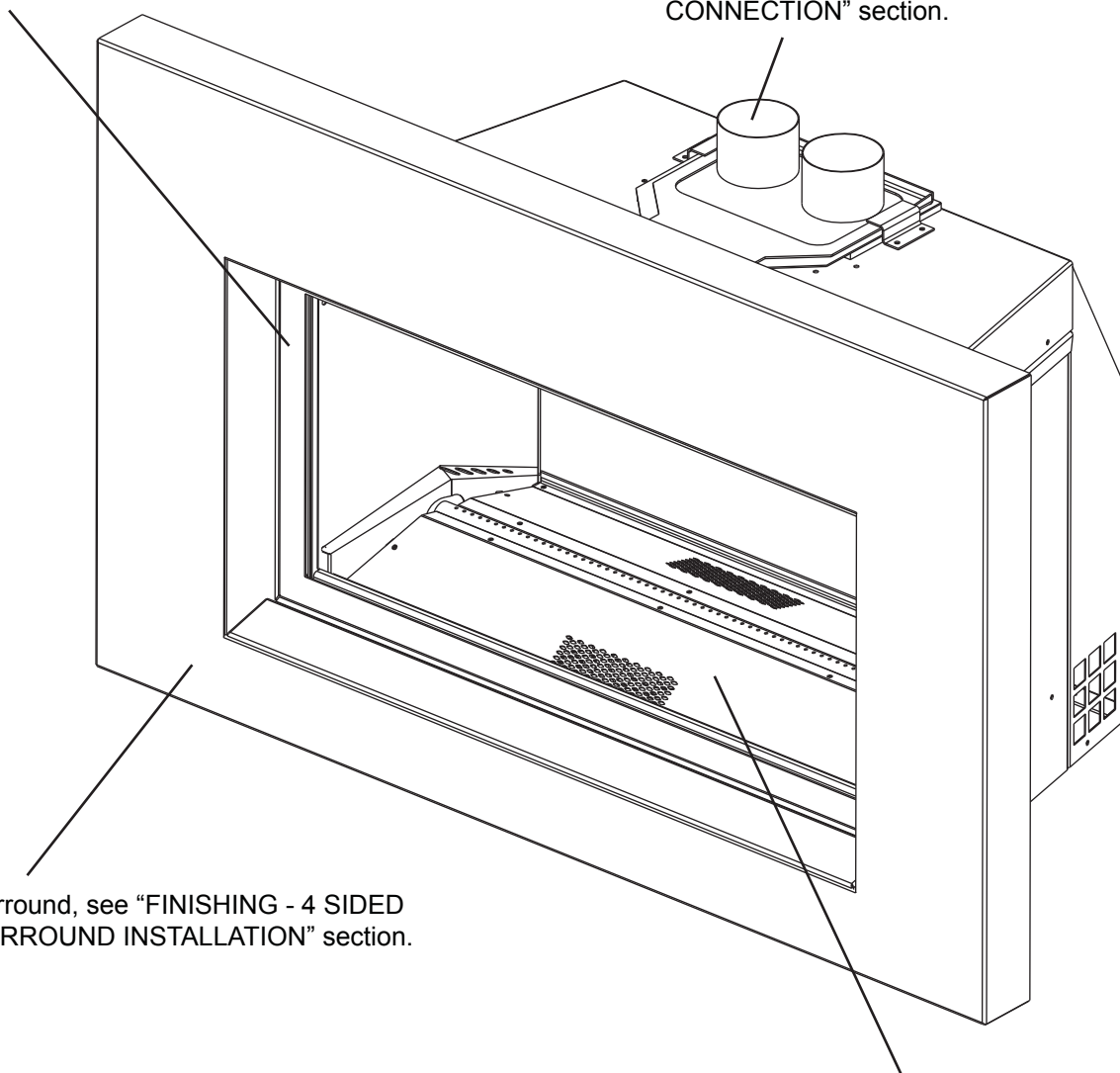

2.0 INTRODUCTION

WARNING

- **THIS APPLIANCE IS HOT WHEN OPERATED AND CAN CAUSE SEVERE BURNS IF CONTACTED.**
- Do not operate appliance before reading and understanding operating instructions. Failure to operate appliance according to operating instructions could cause fire or injury.
- Risk of fire or asphyxiation do not operate appliance with fixed glass removed.
- Do not connect 110 volts to the control valve.
- Risk of burns. The appliance should be turned off and cooled before servicing.
- Do not install damaged, incomplete or substitute components.
- Risk of cuts and abrasions. Wear protective gloves and safety glasses during installation. Sheet metal edges may be sharp.
- Do not burn wood or other materials in this appliance.
- Young children should be carefully supervised when they are in the same room as the appliance. Toddlers, young children and others may be susceptible to accidental contact burns. A physical barrier is recommended if there are at risk individuals in the house. To restrict access to an appliance or stove, install an adjustable safety gate to keep toddlers, young children and other at risk individuals out of the room and away from hot surfaces.
- Clothing or other flammable material should not be placed on or near the appliance.
- Due to high temperatures, the appliance should be located out of traffic and away from furniture and draperies.
- Ensure you have incorporated adequate safety measure to protect infants/toddlers from touching hot surfaces.
- Even after the appliance is out, the glass and/or screen will remain hot for an extended period of time.
- Check with your local hearth specialty dealer for safety screens and hearth guards to protect children from hot surfaces. These screens and guards must be fastened to the floor.
- Any safety screen or guard removed for servicing must be replaced prior to operating the appliance.
- It is imperative that the control compartments, burners and circulating blower and its passageway in the appliance and venting system are kept clean. The appliance and its venting system should be inspected before use and at least annually by a qualified service person. More frequent cleaning may be required due to excessive lint from carpeting, bedding material, etc. The appliance area must be kept clear and free from combustible materials, gasoline and other flammable vapors and liquids.
- Under no circumstances should this appliance be modified.
- This appliance must not be connected to a chimney flue pipe serving a separate solid fuel burning appliance.
- Do not use this appliance if any part has been under water. Immediately call a qualified service technician to inspect the appliance and to replace any part of the control system and any gas control which has been under water.
- Do not operate the appliance with the glass door removed, cracked or broken. Replacement of the glass should be done by a licensed or qualified service person.
- Do not strike or slam shut the appliance glass door.
- When equipped with pressure relief doors, they must be kept closed while the appliance is operating to prevent exhaust fumes containing carbon monoxide, from entering into the home. Temperatures of the exhaust escaping through these openings can also cause the surrounding combustible materials to overheat and catch fire.
- Only doors / optional fronts certified with the unit are to be installed on the appliance.
- Keep the packaging material out of reach of children and dispose of the material in a safe manner. As with all plastic bags, these are not toys and should be kept away from children and infants.
- As with any combustion appliance, we recommend having your appliance regularly inspected and serviced as well as having a Carbon Monoxide Detector installed in the same area to defend you and your family against Carbon Monoxide.

2.1 DIMENSIONS

FIGURE 2.1a-c

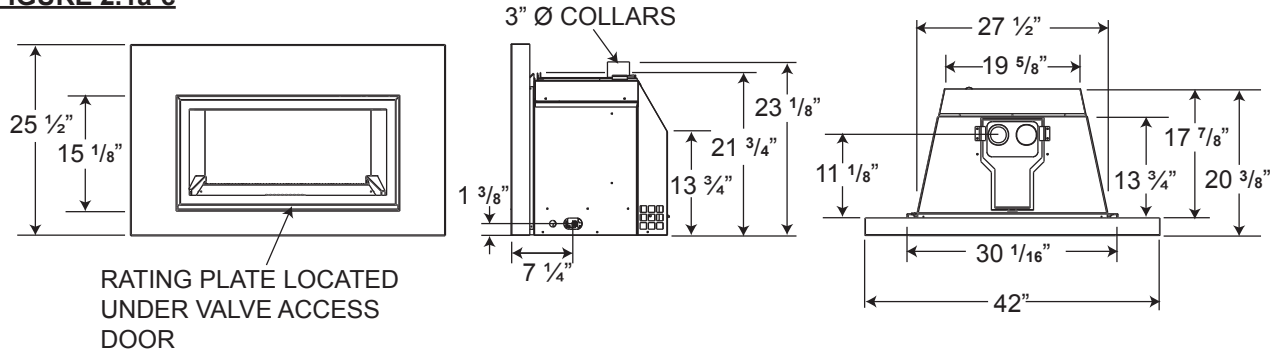

2.2 GENERAL INSTRUCTIONS

! WARNING
ALWAYS LIGHT THE PILOT WHETHER FOR THE FIRST TIME OR IF THE GAS SUPPLY HAS RAN OUT, WITH THE GLASS DOOR OPENED OR REMOVED.
PROVIDE ADEQUATE CLEARANCE FOR SERVICING AND OPERATING THE APPLIANCE.
PROVIDE ADEQUATE VENTILATION.
NEVER OBSTRUCT THE FRONT OPENING OF THE APPLIANCE.
OBJECTS PLACED IN FRONT OF THE APPLIANCE MUST BE KEPT A MINIMUM OF 48" FROM THE FRONT FACE OF THE UNIT.
FIRE RISK. EXPLOSION HAZARD.
HIGH PRESSURE WILL DAMAGE VALVE. DISCONNECT GAS SUPPLY PIPING BEFORE PRESSURE TESTING GAS LINE AT TEST PRESSURES ABOVE 1/2 PSIG. CLOSE THE MANUAL SHUT-OFF VALVE BEFORE PRESSURE TESTING GAS LINE AT TEST PRESSURES EQUAL TO OR LESS THAN 1/2 PSIG.
USE ONLY WOLF STEEL APPROVED OPTIONAL ACCESSORIES AND REPLACEMENT PARTS WITH THIS APPLIANCE. USING NON-LISTED ACCESSORIES (BLOWERS, DOORS, LOUVRES, TRIMS, GAS COMPONENTS, VENTING COMPONENTS, ETC.) COULD RESULT IN A SAFETY HAZARD AND WILL VOID THE WARRANTY AND CERTIFICATION.

THIS GAS APPLIANCE SHOULD BE INSTALLED AND SERVICED BY A QUALIFIED INSTALLER to conform with local codes. Installation practices vary from region to region and it is important to know the specifics that apply to your area, for example in Massachusetts State:

- This product must be installed by a licensed plumber or gas fitter when installed within the commonwealth of Massachusetts.
- The appliance damper must be removed or welded in the open position prior to installation of a appliance insert or gas log.
- The appliance off valve must be a "T" handle gas cock.
- The flexible connector must not be longer than 36 inches.
- A Carbon Monoxide detector is required in all rooms containing gas fired appliances.
- The appliance is not approved for installation in a bedroom or bathroom unless the unit is a direct vent sealed combustion product.

The installation must conform with local codes or, in absence of local codes, the National Gas and Propane Installation Code CSA B149.1 in Canada, or the National Fuel Gas Code, ANSI Z223.1 / NFPA 54 in the United States. Suitable for mobile home installation if installed in accordance with the current standard CAN/CSA Z240MH Series, for gas equipped mobile homes, in Canada or ANSI Z223.1 and NFPA 54 in the United States.

As long as the required clearance to combustibles is maintained, the most desirable and beneficial location for an appliance is in the center of a building, thereby allowing the most efficient use of the heat created. The location of windows, doors and the traffic flow in the room where the appliance is to be located should be considered. If possible, you should choose a location where the vent will pass through the house without cutting a floor or roof joist.



We suggest that our gas hearth products be installed and serviced by professionals who are certified in the U.S. by the National Fireplace Institute® (NFI) as NFI Gas Specialists

4.1

2.3 GENERAL INFORMATION

FOR YOUR SATISFACTION, THIS APPLIANCE HAS BEEN TEST-FIRED TO ASSURE ITS OPERATION AND QUALITY!

CDI-30G		
	NG	LP
Altitude (FT)	0-4,500	0-4500
Max. Input (BTU/HR)	24,500	24,500
Max. Output (BTU/HR)	20,825	20,825
Efficiency (w/the fan on)	85%	85%
A.F.U.E.	82%	82%
Min. Inlet Gas Supply Pressure	4.5" Water Column	11" Water Column
Max. Inlet Gas Supply Pressure	7" Water Column	13" Water Column
Manifold Pressure (Under Flow Conditions)	3.5" Water Column	10" Water Column

When the appliance is installed at elevations above 4,500ft, and in the absence of specific recommendations from the local authority having jurisdiction, the certified high altitude input rating shall be reduced at the rate of 4% for each additional 1,000ft. Expansion / contraction noises during heating up and cooling down cycles are normal and to be expected.

This appliance is not approved for closet or recessed installations. It is approved for bathroom, bedroom and bed-sitting room installations and is suitable for mobile homes. The natural gas model is suitable for installation in a mobile home that is permanently positioned on its site and fuelled with natural gas.

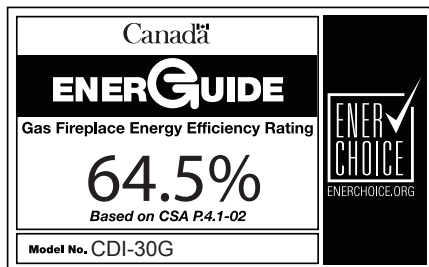

2.4 RATING PLATE INFORMATION

CERTIFIED UNDER / HOMOLOGUE SELON LES NORMES: CSA 2.33b-2009, ANSI Z21.88b-2009 VENTED GAS FIREPLACE HEATER / FOYER DE CHAUFFAGE AU GAZ AVEC EVACUATION.		DIRECT VENT GAS FIREPLACE. APPROVED FOR BEDROOM, BATHROOM AND BED-SITTING ROOM INSTALLATION. SUITABLE FOR MOBILE HOME INSTALLATION IF INSTALLED IN ACCORDANCE WITH THE CURRENT STANDARD CAN/CSA Z240MH SERIES GAS EQUIPPED MOBILE HOMES, IN CANADA OR IN THE UNITED STATES THE MANUFACTURED HOME CONSTRUCTION AND SAFETY STANDARD, TITLE 24 CFR, PART 3280. WHEN THIS US STANDARD IS NOT APPLICABLE USE THE STANDARD FOR FIRE SAFETY CRITERIA FOR MANUFACTURED HOME INSTALLATIONS, SITES AND COMMUNITIES, ANSI / NFPA 501A.	
		FOYER A GAZ VENTILE DIRECT. HOMOLOGUE POUR INSTALLATION DANS UNE CHAMBRE A COUCHER, UNE SALLE DE BAIN ET UN STUDIO. APPROPRIE POUR INSTALLATION DANS UNE MAISON MOBILE SI SON INSTALLATION CONFORME AUX EXIGENCES DE LA NORME CAN/CSA Z240MH SERIE DE MAISONS MOBILES EQUIPEES AU GAZ, EN VIGUEUR AU CANADA OU AUX ETATS-UNE DE LA NORME DE SECURITE ET DE CONSTRUCTION DE MAISONS MANUFACTUREES, TITRE 24 CFR, SECTION 3280. DANS LE CAS OU CETTE NORME D'ETATS-UNIS NE PEUT ETRE APPLIQUEE, SE REFERER A LA NORME RELATIVE AU CRITERE DE MESURES DE SECURITE CONTRE L'INCENDIE POUR LES INSTALLATIONS DANS LES MAISONS MANUFACTURES, LES SITES ET LES COMMUNAUTES, ANSI/NFPA 501A.	
REFERENCE # W/N 16479 CERTIFIED FOR CANADA AND CERTIFIEE POUR CANADA ET USA		MODEL <input type="checkbox"/> GDI-30GN / CDI-30GN	
ALTITUDE / ELEVATION INPUT / ALIMENTATION REDUCED INPUT / ALIMENTATION REDUITE ORIFICE		MODEL <input type="checkbox"/> GDI-30GP / CDI-30GP	
0-4500FT 24,500 BTU/h 15,000BTU/h #43		0-4500FT 24,500 BTU/h 19,000 BTU/h #54	
MINIMUM AND MAXIMUM VERTICAL VENT LENGTHS ARE 10 FEET AND 40 FEET RESPECTIVELY. LES LONGUEURS VERTICALES MINIMALES ET MAXIMALES SONT 10 PIEDS ET 40 PIEDS RESPECTIVEMENT.		MINIMUM AND MAXIMUM VERTICAL VENT LENGTHS ARE 8 FEET AND 40 FEET RESPECTIVELY. LES LONGUEURS VERTICALES MINIMALES ET MAXIMALES SONT 8 PIEDS ET 40 PIEDS RESPECTIVEMENT.	
MANIFOLD PRESSURE: 3.5" D'UNE COLONNE D'EAU (NG) PRESSION AU COLLECTEUR: 3.5" D'UNE COLONNE D'EAU (NG)		MANIFOLD PRESSURE: 10 INCHES W.C.(LP) PRESSION AU COLLECTEUR: 10" D'UNE COLONNE D'EAU (P)	
MIN SUPPLY PRESSURE: 4.5" W.C.(NG) PRESSION D'ALIMENTATION MIN: 4.5" D'UNE COLONNE D'EAU (NG)		MIN SUPPLY PRESSURE: 11" W.C. (LP) PRESSION D'ALIMENTATION MIN: 11" D'UNE COLONNE D'EAU (P)	
MAX. SUPPLY PRESSURE: 7" W.C. (NG) PRESSION D'ALIMENTATION MAX: 7" D'UNE COLONNE D'EAU (NG)		MAX. SUPPLY PRESSURE: 13" W.C. (LP) PRESSION D'ALIMENTATION MAX: 13" D'UNE COLONNE D'EAU (P)	
NOT FOR USE WITH SOLID FUEL		UN COMBUSTIBLE SOLIDE NE DOIT PAS ETRE UTILISE AVEC CET APPAREIL	
FOR USE WITH GLASS DOORS CERTIFIED WITH THIS UNIT ONLY. WARNING: DO NOT ADD ANY MATERIAL TO THE APPLIANCE, WHICH WILL COME IN CONTACT WITH THE FLAMES, OTHER THAN THAT SUPPLIED BY THE MANUFACTURER WITH THE APPLIANCE.		UTILISER AVEC LES PORTES VITREES HOMOLOGUEES SEULEMENT AVEC CETTE UNITE. AVERTISSEMENT: N'AJOUTEZ PAS A CET APPAREIL AUCUN MATERIAU DEVANT ENTRER EN CONTACT AVEC LES FLAMMES AUTRE QUE CELUI QUI EST FOURNI AVEC CET APPAREIL PAR LE FABRICANT.	
ELECTRICAL RATING: 115V 1.5AMP 60HZ THE APPLIANCE MUST BE VENTED USING THE APPROPRIATE WOLF STEEL VENT KITS. SEE OWNERS INSTALLATION MANUAL FOR VENTING SPECIFICS, PROPER REINSTALLATION AND RESEALING IS NECESSARY AFTER SERVICING THE VENT-AIR INTAKE SYSTEM.		CLASS.: 115V 1.5AMP 60HZ L'APPAREIL DOIT EVACUER SES GAZ EN UTILISANT L'ENSEMBLE D'EVACUATION PROPRE A WOLF STEEL. REFERER AU MANUEL D'INSTALLATION DE PROPRIETAIRE POUR L'EVACUATION PRECISE. IL EST IMPORTANT DE BIEN REINSTALLER ET RECELLER L'EVENT APRES AVOIR ASSURE LE MAINTIEN DU SYSTEME DE PRISE D'AIR.	
WARNING: FOR INSTALLATION INTO A VENTED NON-COMBUSTIBLE FIREPLACE ONLY, THE MINIMUM FIREPLACE SIZE IS: HEIGHT 21.75", DEPTH 18", WIDTH 28.0". THE MINIMUM INSIDE FLUE SIZE IS 6", THE MINIMUM DISTANCE, FROM THE BOTTOM OF A COMBUSTIBLE MANTLE PROJECTING A MAXIMUM 3" FROM THE WALL TO THE TOP OF THE UNIT IS 12". SEE OWNERS MANUAL FOR GREATER EXTENSIONS.		ATTENTION: POUR INSTALLATION DANS UN FOYER VENTILE EN MACONNERIE, LES DIMENSIONS MINIMUMS SONT: HAUTEUR 21.75", PROFONDEUR 18", LARGEUR 28.0". LE DIAMETRE INTERIEUR MINIMUM DE CONDUIT D'EVACUATION EST DE 6". LA DISTANCE MINIMALE, DU BAS DU MANTEAU COMBUSTIBLE FORMANT UNE PROJECTION MAXIMALE DE 3" DU MUR AU DESSUS DE LA GARNITURE NORMALE EST 12". REFERER AU MANUEL D'INSTALLATION POUR DES EXTENSIONS PLUS GRANDES.	
		MADE IN CANADA / FABRIQUE AU CANADA WOLF STEEL LTD. BARRIE, ONTARIO CANADA	
		SERIAL NUMBER / NO. DESERIE GDI/CDI-30G	
		W385-0492	

INSTALLER: It is your responsibility to check off the appropriate box on the rating plate according to the model, venting and gas type of the appliance.

For rating plate location, see "DIMENSIONS" section.

2.5 CARE OF GLASS

DO NOT CLEAN GLASS WHEN HOT! DO NOT USE ABRASIVE CLEANERS TO CLEAN GLASS.

Buff lightly with a clean dry soft cloth. Clean both sides of the glass after the first 10 hours of operation with a recommended fireplace glass cleaner. Thereafter clean as required. If the glass is not kept clean permanent discoloration and / or blemishes may result.



5.1

3.0 INSTALLATION

WARNING

RISK OF FIRE, MAINTAIN SPECIFIED AIR SPACE CLEARANCES TO VENT PIPE AND APPLIANCE.

IF USING CO-AXIAL VENTING WITH SPACERS, THE VENT SYSTEM MUST BE SUPPORTED EVERY 3 FEET FOR BOTH VERTICAL AND HORIZONTAL RUNS. USE SUPPORTS OR EQUIVALENT NON-COMBUSTIBLE STRAPPING TO MAINTAIN THE REQUIRED CLEARANCE FROM COMBUSTIBLES. USE WOLF STEEL LTD. SUPPORT RING ASSEMBLY W010-0370 OR EQUIVALENT NON-COMBUSTIBLE STRAPPING TO MAINTAIN THE MINIMUM CLEARANCE TO COMBUSTIBLES FOR BOTH VERTICAL AND HORIZONTAL RUNS. SPACERS ARE ATTACHED TO THE INNER PIPE AT PREDETERMINED INTERVALS TO MAINTAIN AN EVEN AIR GAP TO THE OUTER PIPE. THIS GAP IS REQUIRED FOR SAFE OPERATION. A SPACER IS REQUIRED AT THE START, MIDDLE AND END OF EACH ELBOW TO ENSURE THIS GAP IS MAINTAINED. THESE SPACERS MUST NOT BE REMOVED.

Clean out ashes from the inside of the wood-burning appliance. Make sure that the chimney and wood-burning appliance are in a clean and sound condition and constructed of non-combustible materials. If necessary have any repair work done by a qualified person before installing the insert. Remove the existing appliance damper or lock into an open position.

Using screws, attach the appliance warning tag to the inside of the firebox of the appliance into which the insert is being installed.

The sheet-metal parts of the appliance, in which the gas appliance insert is to be installed, must not be cut.

If the wood-burning factory-built appliance has no gas access hole(s) provided, an access hole of 1½ inch or less may be drilled through the lower sides or bottom of the appliance in a proper workman like manner. This access hole must be plugged with non-combustible insulation after the gas supply line has been installed.

Ensure that existing chimney cleanouts fit properly.

The refractory, glass doors, screen rails, screen mesh and log grates may be removed from the existing appliance before installing the gas appliance insert.

Smoke shelves, shields and baffles may be removed if attached by mechanical fasteners.

The ventilation openings in the existing appliance may be obstructed by the backer plates, aluminium trim etc. but these parts are not to be applied so as to have an airtight seal.

68.4

WARNING: THIS FIREPLACE HAS BEEN CONVERTED FOR USE WITH A GAS FIREPLACE INSERT ONLY AND CANNOT BE USED FOR BURNING WOOD OR SOLID FUELS UNLESS ALL ORIGINAL PARTS HAVE BEEN REPLACED AND THE FIREPLACE IS RE-APPROVED BY THE AUTHORITY HAVING JURISDICTION.

ATTENTION: CE FOYER A ETE CONVERTI AFIN D'ETRE UTILISE SEULEMENT COMME FOYER ENCASTRE AU GAZ ET NE PEUT ETRE UTILISE POUR BRULER DU BOIS OU TOUT AUTRE COMBUSTIBLE SOLIDE, SANS QUE TOUTES LES PIECES ORIGINALES AIENT ETE REMPLACEES ET QUE LE FOYER SOIT APPROUVE DE NOUVEAU PAR LES AUTORITES AYANT JURIDICTION.

ADVERTENCIA: ESTA CHIMENEA SE REMODELÓ PARA USARSE SOLO CON UNA INSERCIÓN DE CHIMENEA A GAS Y NO PUEDE USARSE PARA QUEMAR MADERA NI COMBUSTIBLES SÓLIDOS, A MENOS QUE SE HAYAN REEMPLAZADO TODAS LAS PIEZAS ORIGINALES, Y LA AUTORIDAD JURISDICCIONAL LA HAYA VUELTO A APROBAR.

W385-0199_B

3.1 INSERT LEVELLING

Move the insert close to its final position. This appliance is equipped with levelling screws located on the base. Level using the levelling screws. Levelling the appliance will eliminate rocking or excessive noise when the fan is in operation. Once the appliance is level, move it partially into place to allow for all connections to be made. It is not practical to level the insert once it has been installed. Determine the required depth prior to installing the unit and adjust the levelling screws accordingly.

67.2

3.2 CHIMNEY CONNECTION

Chimney installation must conform to both national and local code requirements. The chimney must be lined with one 2" or 3" diameter liner for intake and one 3" diameter liner for exhaust. The minimum and maximum vent lengths are 10 and 35 feet respectively. Recommended Continental kits come in 3 lengths:

1-2" & 1-3" DOUBLE PLY ALUMINUM LINER-INLET AND EXHAUST & 2-3" TO 2" REDUCER:

GDI-2320KT	VENT KIT 20FT
GDI-2325KT	VENT KIT 25FT
GDI-2335KT	VENT KIT 35FT

2-3" DOUBLE PLY ALUMINUM LINER-INLET AND EXHAUST:

GDI-320KT	VENT KIT 20FT
GDI-325KT	VENT KIT 25 FT
GDI-335KT	VENT KIT 35 FT

While the liners must be continuous from the appliance to the chimney cap, to achieve the needed length, they may be coupled, using an approved coupler. We recommend that exhaust vents that pass through unheated spaces, such as tall exterior chimneys, be wrapped in a protective sleeve to minimize condensation and reverse flow symptoms. See Trouble Shooting for details.

This appliance is approved for use with a 2" liner for air intake and a 3" liner for exhaust. For best performance, however, it is recommended to use two 3" liners. If a 2" liner is used for the intake, it may be necessary to adjust the primary air shutter.

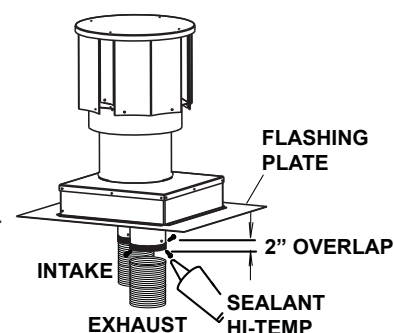
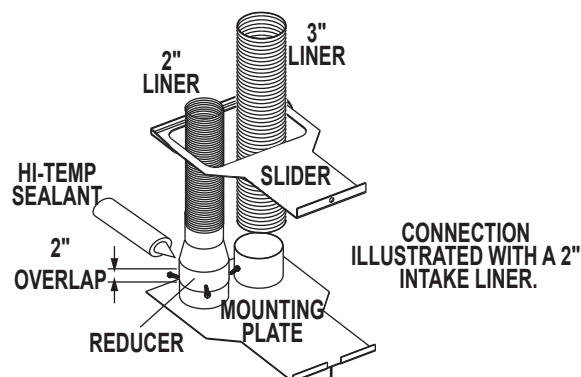

FIGURE 3.2.1

- 3.2.1 OUTSIDE:** Slip the one end of a liner a minimum of 2" over the sleeve of the air terminal. Secure using 3 screws. Then seal the joint and screw heads with high temperature sealant. Repeat with the other liner.

NOTE: We recommend that the other end of the exhaust liner be marked to eliminate the exhaust liner being connected to the intake collar at the appliance.



- 3.2.2** Gently stretch the liners to the required lengths and insert into the chimney. Trim and fit the flashing plate to suit the chimney termination. Place the air terminal onto the top of the chimney. Make weather tight by sealing with caulking (not supplied). Fasten to the chimney with screws and plugs (not supplied).

- 3.2.3 INSIDE:** Remove the securing screw from the front of the vent mounting plate. Pull the vent mounting plate only, back into the track, to the front stop. Start the slider back into position. Re-secure the screw. The insert may now be pushed into its final position inside the wood burning appliance, and the screw tightened until the slider has been pulled tight to the front stop.

- 3.2.4** Route the flex liners through the slider. Attach and secure the liners to the vent mounting plate using the same procedure as before, ensuring that the marked exhaust liner is attached to the exhaust collar.

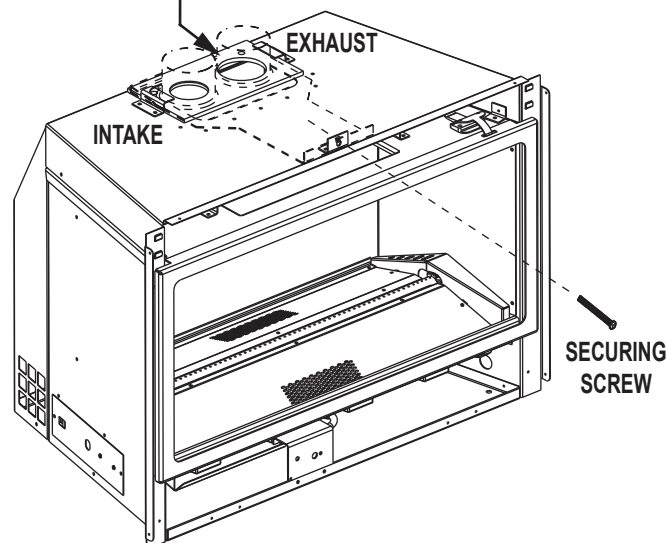

3.3 GAS INSTALLATION

 WARNING
RISK OF FIRE, EXPLOSION OR ASPHYXIATION. ENSURE THERE ARE NO IGNITION SOURCES SUCH AS SPARKS OR OPEN FLAMES.
SUPPORT GAS CONTROL WHEN ATTACHING GAS SUPPLY PIPE TO PREVENT DAMAGING GAS LINE.
ALWAYS LIGHT THE PILOT WHETHER FOR THE FIRST TIME OR IF THE GAS SUPPLY HAS RUN OUT WITH THE GLASS DOOR OPENED OR REMOVED. PURGING OF THE GAS SUPPLY LINE SHOULD BE PERFORMED BY A QUALIFIED SERVICE TECHNICIAN. ASSURE THAT A CONTINUOUS GAS FLOW IS AT THE BURNER BEFORE CLOSING THE DOOR. ENSURE ADEQUATE VENTILATION. FOR GAS AND ELECTRICAL LOCATIONS, SEE "DIMENSION" SECTION.
ALL GAS CONNECTIONS MUST BE CONTAINED WITHIN THE APPLIANCE WHEN COMPLETE.
HIGH PRESSURE WILL DAMAGE VALVE. DISCONNECT GAS SUPPLY PIPING BEFORE TESTING GAS LINE AT TEST PRESSURES ABOVE 1/2 PSIG.
VALVE SETTINGS HAVE BEEN FACTORY SET, DO NOT CHANGE.

Installation and servicing to be done by a qualified installer. **Do not use open flame.**

- 3.3.1** Move the appliance into position and secure.
- 3.3.2** If equipped with a flex connector the appliance is designed to accept a 1/2" gas supply. Without the connector it is designed to accept a 3/8" gas supply. The appliance is equipped with a manual shut off valve to turn off the gas supply to the appliance.
- 3.3.3** Connect the gas supply in accordance to local codes. In the absence of local codes, install to the current CAN/CSA-B149.1 Installation Code in Canada or to the current National Fuel Gas Code, ANSI Z223.1 / NFPA 54 in the United States.
- 3.3.4** When flexing any gas line, support the gas valve so that the lines are not bent or kinked.
- 3.3.5** Check for gas leaks by brushing on a soap and water solution.

30.1

3.4 OPTIONAL WALL SWITCH / THERMOSTAT

For ease of accessibility, an optional remote wall switch or millivolt thermostat may be installed in a convenient location. Route 2 strand solid core millivolt wire from the gas appliance to the wall switch / millivolt thermostat. The recommended maximum lead length depends on the wire size:

WIRE SIZE	MAX. LENGTH
14 gauge	100 feet
16 gauge	60 feet
18 gauge	40 feet

Disconnect one of the wire leads to the on/off switch, then connect the wire leads from the optional thermostat / wall switch / remote. See "WIRING DIAGRAM" section.

4.0 FRAMING

! WARNING
MINIMUM CLEARANCE TO COMBUSTIBLES MUST BE MAINTAINED OR A SERIOUS FIRE HAZARD COULD RESULT.
NEVER OBSTRUCT THE FRONT OPENING OF THE APPLIANCE.

This insert must be recessed into a vented noncombustible wood-burning appliance (prefabricated or masonry) only. The minimum appliance opening size in which the appliance is to be installed is:

HEIGHT 21.75" WIDTH 28" DEPTH 18"
The minimum allowable chimney flue size is 6" round.

The minimum distance, from the bottom of a combustible mantel projecting 3" maximum from the wall to the top of the front, is 8".

4.1 MINIMUM MANTEL CLEARANCES

! WARNING
RISK OF FIRE, MAINTAIN ALL SPECIFIED AIR SPACE CLEARANCES TO COMBUSTIBLES. FAILURE TO COMPLY WITH THESE INSTRUCTIONS MAY CAUSE A FIRE OR CAUSE THE APPLIANCE TO OVERHEAT. ENSURE ALL CLEARANCES (I.E. BACK, SIDE, TOP, VENT, MANTEL, FRONT, ETC.) ARE CLEARLY MAINTAINED.
WHEN USING PAINT OR LACQUER TO FINISH THE MANTEL, THE PAINT OR LACQUER MUST BE HEAT RESISTANT TO PREVENT DISCOLOURATION.

73.1

Combustible mantel clearance can vary according to the mantel depth. Use the graph to help evaluate the clearance needed. These same requirements apply to any combustibles protruding on either side of the appliance.

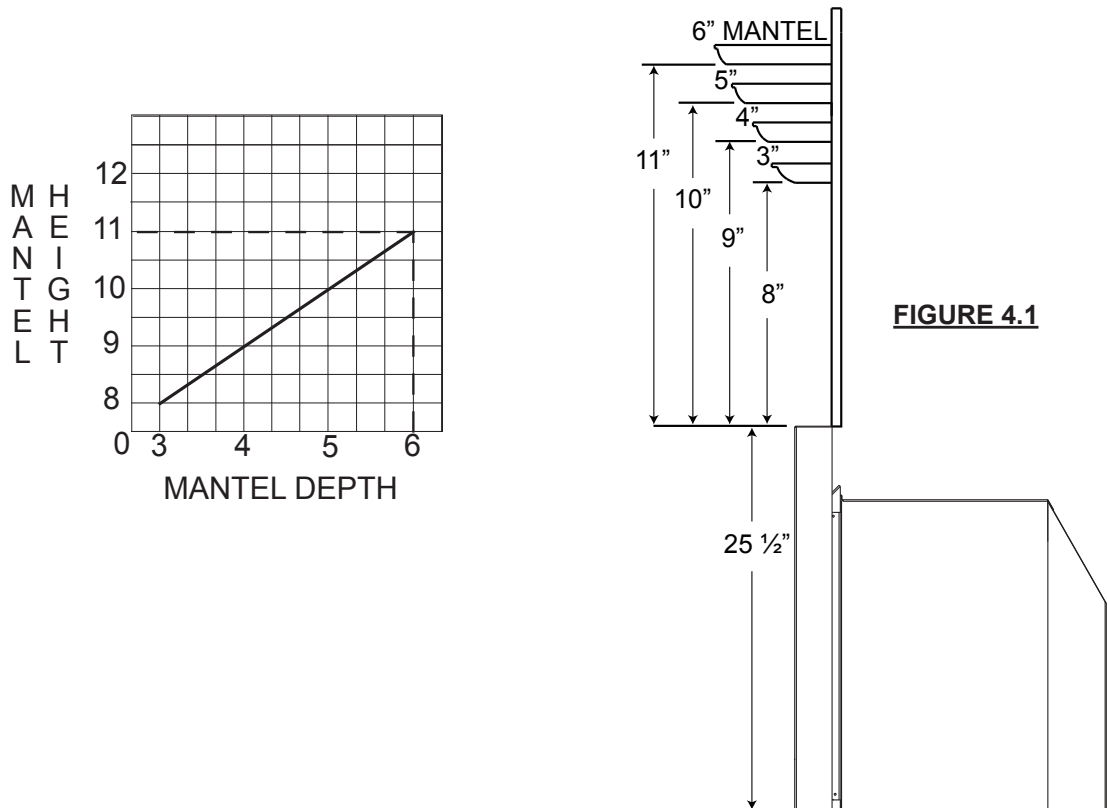

5.0 FINISHING



WARNING

ENSURE THE UNIT IS COMPLETELY COOL BEFORE STARTING INSTALLATION.

5.1 4 SIDED SURROUND

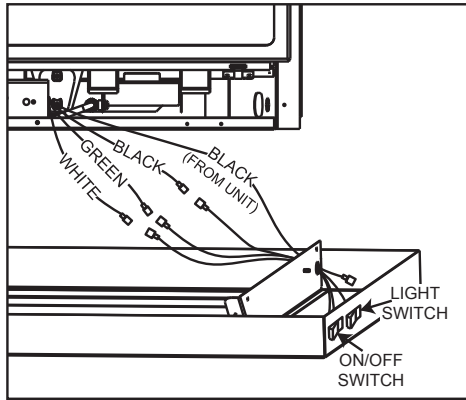

FIGURE 5.1a

5.1.1 Connect the two black on/off switch wires (already connected to the frame) to the white and green wires located on the lower right hand side of the appliance control compartment.

5.1.2 Connect the black light switch wire (already connected to the frame) to the transformer wire (black with blue connector).

5.1.3 Slide the black 48" wire from the control compartment through the bushing in the bottom right corner of the frame and connect it to the light switch.

5.1.4 Line up the holes in the back of the frame with the holes in the appliance. Secure using the screws provided.

5.1.5 Align the notches on the side of the valve access door with the shoulder screws, making sure it moves up and down freely.

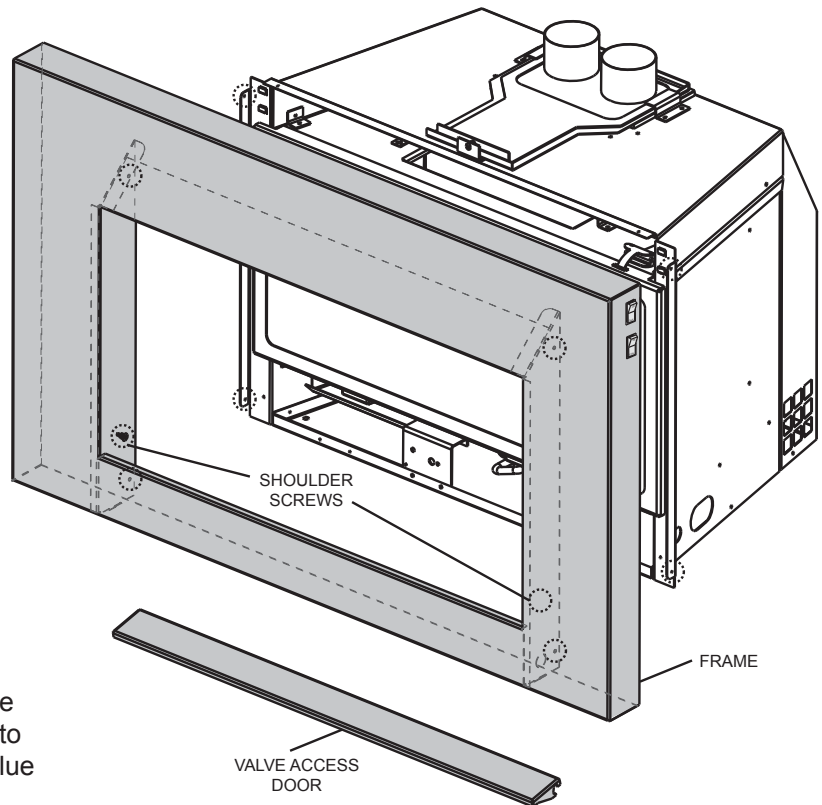

FIGURE 5.1b

5.2 DOOR REMOVAL AND INSTALLATION

5.2.1 Before servicing, allow the appliance to cool completely.

5.2.2 Release the top and bottom door latches, located at the right side of the door.

5.2.3 To access the lower door latch lift up on the front edge of the valve access door to open.

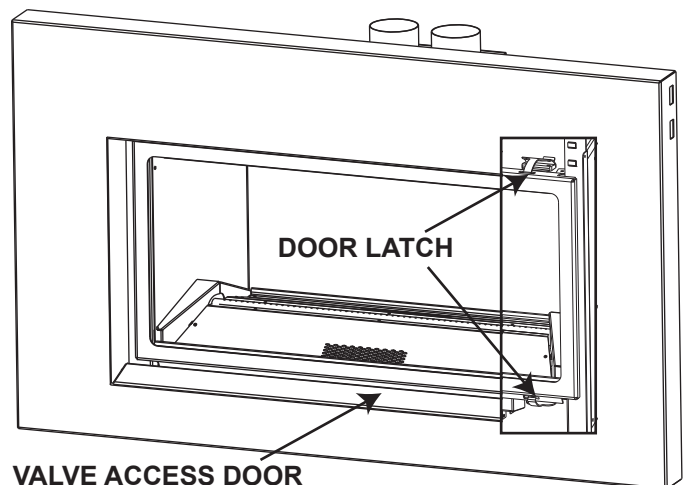

FIGURE 5.2

VALVE ACCESS DOOR

5.3 DOOR GLASS REPLACEMENT

! WARNING
DO NOT USE SUBSTITUTE MATERIALS.
GLASS MAY BE HOT, DO NOT TOUCH GLASS UNTIL COOLED.
CARE MUST BE TAKEN WHEN REMOVING AND DISPOSING OF ANY BROKEN DOOR GLASS OR DAMAGED COMPONENTS. BE SURE TO VACUUM UP ANY BROKEN GLASS FROM INSIDE THE APPLIANCE BEFORE OPERATION.
DO NOT STRIKE, SLAM OR SCRATCH GLASS. DO NOT OPERATE APPLIANCE WITH GLASS REMOVED, CRACKED, BROKEN OR SCRATCHED.

- 5.3.1** Place the door frame face down careful not to scratch the paint.
- 5.3.2** Center the gasketed glass inside the door frame with the thick side of the gasket facing up.
- 5.3.3** Bend the glass retainers located along the edge of the door frame over the gasket holding the glass in place. Careful not to break the glass.

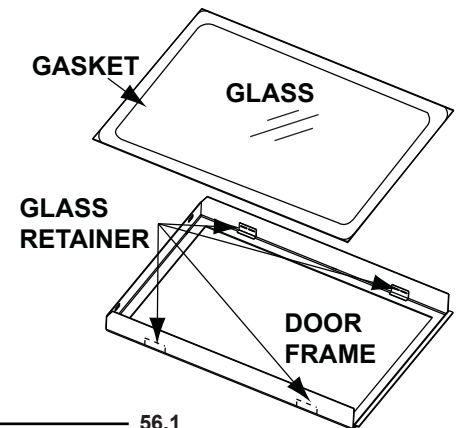

FIGURE 5.3

56.1

5.4 MEDIA TRAY INSTALLATION

Secure the media tray to the burner using 6 screws (W570-0001).

When removing the media tray make sure the glass media is away from the center of the screen, exposing the burner, remove screws and lift media tray out.

When replacing burner, absolutely no glass media can be in cup surrounding the orifice. **HINT: If glass falls into cup and surrounds the orifice, insert a clean bag into a vacuum cleaner and vacuum out glass media. Replacement glass media can be ordered from Wolf Steel Ltd.**

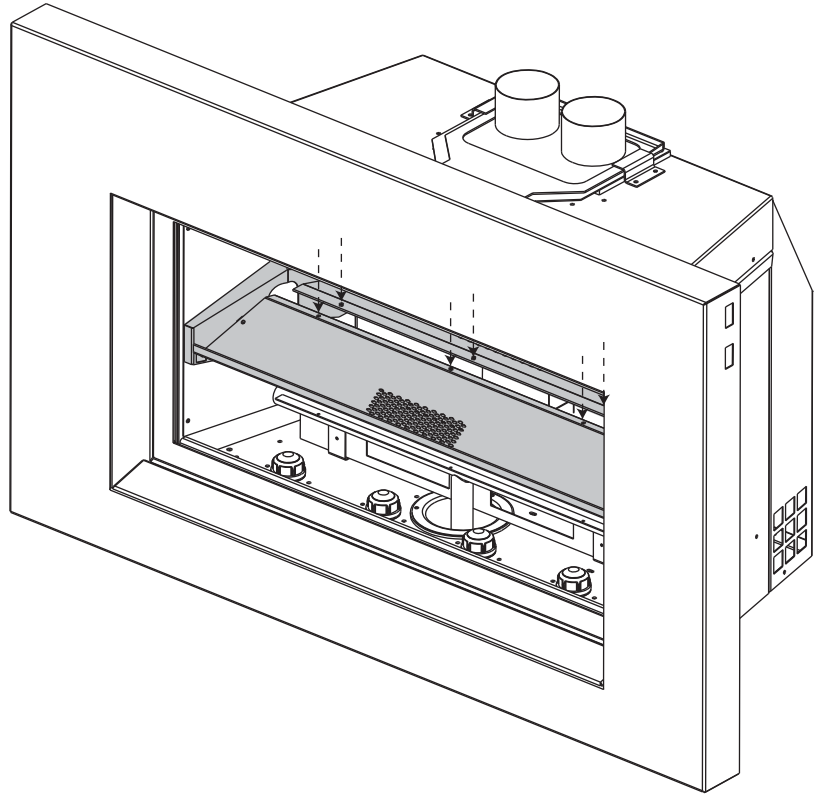

FIGURE 5.4

5.5 MEDIA INSTALLATION

! WARNING

CLEAN THE GLASS MEDIA PRIOR TO INSTALLATION. BEFORE APPLYING THE CLEANED GLASS, ENSURE THAT IT IS DRY.

DO NOT CHANGE OR SUBSTITUTE THE GLASS MEDIA MATERIAL PROVIDED WITH THIS APPLIANCE. IF REPLACING, USE ONLY THE REPLACEMENT GLASS MEDIA AVAILABLE FROM YOUR AUTHORIZED DEALER / DISTRIBUTOR.

GLASS MEDIA OVER THE BURNER MUST NOT BE MORE THAN ONE LAYER HIGH. MORE THAN ONE LAYER OVER THE BURNER WILL CAUSE FLAME LIFTING AND SOOTING PROBLEMS.

Evenly spread the glass media onto the media tray, covering the burner tube and following the natural shape of the tray.

NOTE: The distribution of glass media over the burner tube will influence the flame height. When the flames impinge on the glass, the glass may discolour slightly and the edges may soften.

CLEANING GLASS MEDIA

Glass media may have a fine oil residue that needs to be cleaned prior to installation. Clean the glass with mild dish soap, drain, rinse thoroughly and dry before placing over the burner.

5.6 LAMP REPLACEMENT

This appliance comes equipped with our "Night Light™". If in the event the lamp needs to be replaced, follow these instructions.

- 5.6.1 Turn off all electrical supply.
- 5.6.2 Remove the glass media and media tray from the firebox, see "MEDIA TRAY INSTALLATION" section.
- 5.6.3 Unscrew the lens cover. **NOTE: Do not handle the lamp with bare fingers, protect with a clean dry cloth.**
- 5.6.4 The lamp will pull straight out of the socket. Replace with Wolf Steel Ltd. parts only (W387-0009), as lamp and lens are special "high temperature" products.
- 5.6.5 Replace lens.
- 5.6.6 Replace glass media and media tray.



FIGURE 5.6

5.7 LAMP ASSEMBLY REPLACEMENT

! WARNING

THE FRONT OF THE APPLIANCE BECOMES VERY HOT DURING OPERATION. LET THE APPLIANCE COOL COMPLETELY BEFORE CONDUCTING SERVICE.

- 5.7.1 Remove the glass media and media tray, see "MEDIA TRAY INSTALLATION" section.
- 5.7.2 Remove the 2 screws holding the lamp assembly shield.
- 5.7.3 Compress the 3 retainer fins and lift out the lamp assembly. Disconnect the wires.
- 5.7.4 Replace lamp assembly by aligning key hole and snap into place. Re-connect the wires.
- 5.7.5 Re-install the lamp assembly shield.
- 5.7.6 Re-install media tray and glass media.

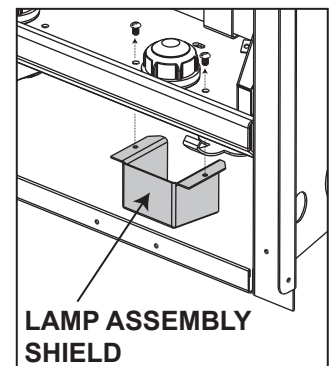

FIGURE 5.7.2

NOTE: When removing the media tray make sure the glass media is away from the center of the screen, exposing the burner, before lifting media tray out.

When replacing burner, absolutely no glass media can be in cup surrounding the orifice. **HINT:** If glass falls into cup and surrounds the orifice, insert a clean bag into a vacuum cleaner and vacuum out glass media. Replacement glass media can be ordered from Wolf Steel Ltd.



FIGURE 5.7.3

5.8 LOGO PLACEMENT

Remove the backing of the logo supplied and place on the glass viewing door, as indicated.

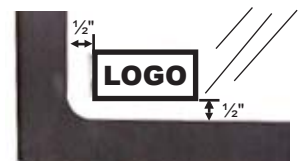

FIGURE 5.8

6.0 REPLACEMENT BLOWER INSTALLATION

⚠ WARNING

RISK OF FIRE AND ELECTRICAL SHOCK.

TURN OFF THE GAS AND ELECTRICAL POWER BEFORE SERVICING THIS APPLIANCE.

USE ONLY WOLF STEEL APPROVED OPTIONAL ACCESSORIES AND REPLACEMENT PARTS WITH THIS APPLIANCE. USING NON-LISTED ACCESSORIES (BLOWERS, DOORS, LOUVRES, TRIMS, GAS COMPONENTS, VENTING COMPONENTS, ETC.) COULD RESULT IN A SAFETY HAZARD AND WILL VOID THE WARRANTY AND CERTIFICATION.

ENSURE THAT THE FAN'S POWER CORD IS NOT IN CONTACT WITH ANY SURFACE OF THE APPLIANCE TO PREVENT ELECTRICAL SHOCK OR FIRE DAMAGE. DO NOT RUN THE POWER CORD BENEATH THE APPLIANCE.

- 6.0.1 Turn off the electrical power and the gas supply to the appliance insert.
- 6.0.2 Open the glass door, see "DOOR REMOVAL AND INSTALLATION" section. Remove the glass media and media tray, see "MEDIA TRAY INSTALLATION" section.
- 6.0.3 Remove the two side porcelain panels by removing the four screws located at the front of the appliance then remove the back porcelain panel.
- 6.0.4 Remove the front blower access cover held on with 4 screws.
- 6.0.5 Remove the rear blower access cover. **NOTE:** Check the blower gasket for damage. Replace if damaged.
- 6.0.6 Disconnect the two blower wires. Remove the blower from the mounting plate and replace. For thermal switch replacement: Remove the mounting bracket secured to the underside of the burner base. Remove the thermal switch from the bracket and replace.
- 6.0.7 Reconnect the two wires. Re-install the blower gasket. Reattach the blower mounting plate and blower access covers. Replace the glass media. Close the glass door.
- 6.0.8 Turn the gas supply and electricity back on. Because the blower is thermally activated, when turned on, it will automatically start approximately 5-15 minutes after lighting the appliance insert and will run for approximately 30-45 minutes after the appliance insert has been turned off. Use of the fan increases the output of heat.
Drywall dust will penetrate into the blower bearings causing irreparable damage and must be prevented from coming into contact with the blower or its compartment. Any damage resulting from this condition is not covered by the warranty policy.

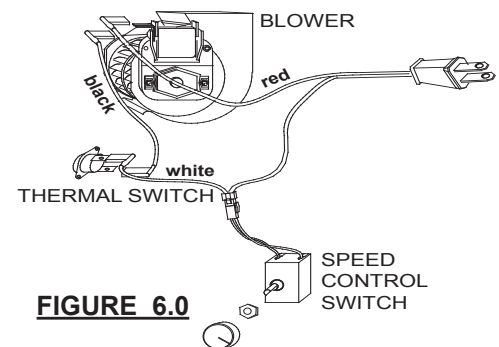

FIGURE 6.0

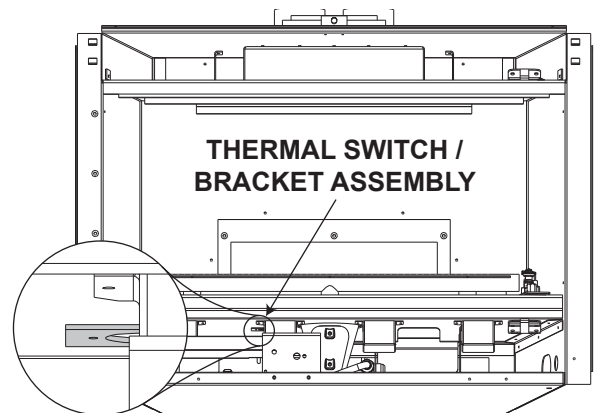
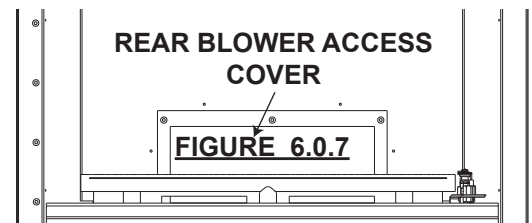
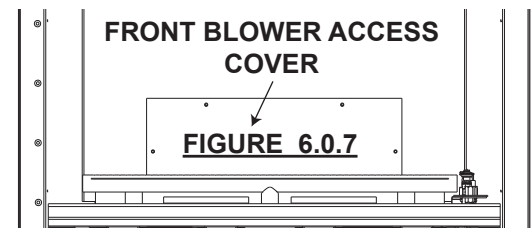

FIGURE 6.0.8

7.0 OPERATION

! WARNING

IF YOU DO NOT FOLLOW THESE INSTRUCTIONS EXACTLY, A FIRE OR EXPLOSION MAY RESULT CAUSING PROPERTY DAMAGE, PERSONAL INJURY OR LOSS OF LIFE.

ALWAYS LIGHT THE PILOT WHETHER FOR THE FIRST TIME OR IF THE GAS SUPPLY HAS RUN OUT WITH THE GLASS DOOR OPENED OR REMOVED.

The on-off switch is located on the front of the appliance in the top right corner.

When lit for the first time, the appliance will emit a slight odour for a few hours. This is a normal temporary condition caused by the "burn-in" of internal paints and lubricants used in the manufacturing process and will not occur again. Simply open a window to sufficiently ventilate the room. After extended periods of non-operation such as following a vacation or a warm weather season, the appliance may emit a slight odour for a few hours. This is caused by dust particles in the heat exchanger burning off. Open a window to sufficiently ventilate the room.

7.1 OPERATING AND LIGHTING INSTRUCTIONS

OPERATING INSTRUCTIONS / INSTRUCTIONS D'OPERATION
FOR YOUR SAFETY READ BEFORE OPERATING / POUR VOTRE SÉCURITÉ LIRE AVANT DE FAIRE FONCTIONNER

<p>WARNING: IF YOU DO NOT FOLLOW THESE INSTRUCTIONS EXACTLY, A FIRE OR EXPLOSION MAY RESULT CAUSING PROPERTY DAMAGE, PERSONAL INJURY OR LOSS OF LIFE. INITIAL LIGHTING OF THE PILOT AND MAIN BURNERS MUST BE DONE WITH THE GLASS DOOR OFF. DO NOT CONNECT VALVE OR WALL SWITCH TO ELECTRICITY. SEE INSTALLATION INSTRUCTIONS.</p> <p>A. THIS FIREPLACE IS EQUIPPED WITH AN IGNITION DEVICE WHICH AUTOMATICALLY LIGHTS THE PILOT. DO NOT TRY TO LIGHT BY HAND. B. BEFORE OPERATING SMELL ALL AROUND THE FIREPLACE AREA FOR GAS AND NEXT TO THE FLOOR BECAUSE SOME GAS IS HEAVIER THAN AIR AND WILL SETTLE ON THE FLOOR. WHAT TO DO IF YOU SMELL GAS:</p> <ul style="list-style-type: none"> • TURN OFF ALL GAS TO THE FIREPLACE. • OPEN WINDOWS. • DO NOT TRY TO LIGHT ANY APPLIANCE. • DO NOT TOUCH ANY ELECTRIC SWITCH; DO NOT USE ANY PHONE IN YOUR BUILDING. • IMMEDIATELY CALL YOUR GAS SUPPLIER FROM A NEIGHBOUR'S PHONE. FOLLOW THE GAS SUPPLIER'S INSTRUCTIONS. • IF YOU CANNOT REACH YOUR GAS SUPPLIER, CALL THE FIRE DEPARTMENT. • DO NOT TRY TO REPAIR ANY PART OF THIS ASSEMBLY. CALL A QUALIFIED SERVICE TECHNICIAN. FORCE OR ATTEMPTED REPAIR MAY RESULT IN A FIRE OR EXPLOSION. • DO NOT USE THIS FIREPLACE IF ANY PART HAS BEEN UNDER WATER. IMMEDIATELY CALL A QUALIFIED SERVICE TECHNICIAN TO INSPECT THE FIREPLACE AND REPLACE ANY PART OF THE CONTROL SYSTEM AND ANY GAS CONTROL WHICH HAS BEEN UNDER WATER. 	<p>ATTENTION: SI CES INSTRUCTIONS NE SONT PAS OBSERVÉES À LA LETTRE, UN FEU OU UNE EXPLOSION POURRAIT S'ENSUIVRE CAUSANT DES DOMMAGES À LA PROPRIÉTÉ, DES BLESSURES CORPORELLES OU PERTE DE VIE. L'ALLUMAGE INITIAL DE LA VEILLEUSE ET DU BRÛLEUR PRINCIPAL DOIT SE FAIRE AVEC LA PORTE VITRÉE ENLEVÉE. NE RACCORDEZ PAS LA SOUPAPE OU L'INTERRUPTEUR MURALE L'ÉLECTRICITÉ. CONSULTEZ LES INSTRUCTIONS D'INSTALLATION.</p> <p>A. CET APPAREIL EST MUNI D'UN DISPOSITIF D'ALLUMAGE QUI ALLUME LA VEILLEUSE AUTOMATIQUEMENT. N'ESSAYEZ PAS D'ALLUMER LA VEILLEUSE MANUELLEMENT. B. AVANT D'ALLUMER SENTEZ L'AIR AUTOUR DE L'APPAREIL ET PRÈS DU PLANCHER (CERTAINS GAZ SONT PLUS LOURDS QUE L'AIR ET SE DÉPOSERONT AU NIVEAU DU PLANCHER) POUR DÉTECTER UNE FUIITE POSSIBLE. QUE FAIRE SI VOUS DÉTECTEZ UNE ODEUR DE GAZ: • COUPEZ L'ALIMENTATION DE GAZ PRINCIPALE. • OUVREZ LES FENÊTRES. • N'ALLUMEZ AUCUN APPAREIL. • NE TOUCHEZ PAS À AUCUN INTERRUPTEUR ÉLECTRIQUE; N'UTILISEZ AUCUN TÉLÉPHONE DANS VOTRE IMMEUBLE. • APPELÉZ IMMÉDIATEMENT VOTRE FOURNISSEUR DE GAZ D'UN TÉLÉPHONE VOISIN ET SUIVEZ SES INSTRUCTIONS. • SI VOUS NE POUVEZ PAS REJOINDRE VOTRE FOURNISSEUR DE GAZ, APPELEZ LE SERVICE DES INCENDIES. C. N'ESSAYEZ PAS DE RÉPARER AUCUNE PIÈCE DE CET ASSEMBLAGE. APPELÉZ UN TECHNICIEN QUALIFIÉ. FORCER OU TENTER DE RÉPARER L'ASSEMBLAGE POURRAIT CAUSER UN FEU OU UNE EXPLOSION. D. N'UTILISEZ PAS CET APPAREIL SI UN DE SES COMPOSANTS À ÉTÉ SUBMÉRGÉ. CONTACTEZ IMMÉDIATEMENT UN TECHNICIEN DE SERVICE QUALIFIÉ POUR INSPECTER L'APPAREIL ET REMPLACER TOUT SYSTÈME DE CONTRÔLE DE GAZ TOUCHÉ PAR L'EAU.</p> <p style="text-align: right;">W385-0460</p>
--	---

LIGHTING INSTRUCTIONS / INSTRUCTIONS D'ALLUMAGE

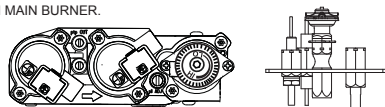
<ol style="list-style-type: none"> 1. STOP! READ ALL INFORMATION OF OPERATING AND LIGHTING INSTRUCTIONS BEFORE PROCEEDING. 2. TURN OFF ELECTRIC POWER TO THE FIREPLACE. 3. THIS FIREPLACE IS EQUIPPED WITH AN IGNITION DEVICE WHICH AUTOMATICALLY LIGHTS THE PILOT. DO NOT TRY TO LIGHT THE PILOT BY HAND. 4. OPEN THE GLASS DOOR. 5. TURN MANUAL SHUTOFF VALVE CLOCKWISE TO OFF. 6. WAIT FIVE (5) MINUTES TO CLEAR OUT ANY GAS. IF YOU SMELL GAS INCLUDING NEAR THE FLOOR, STOP! FOLLOW "B" OF THE OPERATING INSTRUCTIONS. IF YOU DON'T SMELL GAS GO TO THE NEXT STEP. 7. TURN MANUAL SHUTOFF VALVE COUNTER-CLOCKWISE TO ON. 8. CLOSE THE GLASS DOOR. 9. TURN ON ALL ELECTRIC POWER TO THE FIREPLACE. 10. TURN ON MAIN BURNER. 	<ol style="list-style-type: none"> 1. ARRÊTEZ! LISEZ TOUTES LES INSTRUCTIONS DE FONCTIONNEMENT ET D'ALLUMAGE AVANT DE CONTINUER. 2. COUPEZ L'ALIMENTATION ÉLECTRIQUE À L'APPAREIL. 3. CET APPAREIL EST MUNI D'UN DISPOSITIF D'ALLUMAGE QUI ALLUME LA VEILLEUSE AUTOMATIQUEMENT. N'ESSAYEZ PAS D'ALLUMER LA VEILLEUSE MANUELLEMENT. 4. OUVREZ LA PORTE VITRÉE. 5. TOURNÉZ LA SOUPAPE DE SECTIONNEMENT MANUELLE VERS LA DROITE À "OFF". 6. ATTENDEZ CINQ (5) MINUTES POUR QUE LE GAZ PUISSE S'ÉCHAPPER. SI VOUS DÉTECTEZ UNE ODEUR DE GAZ, ARRÊTEZ! SUIVEZ « B » DANS LES INSTRUCTIONS DE FONCTIONNEMENT. S'IL N'Y A PAS D'ODEUR DE GAZ, PASSEZ À L'ÉTAPE SUIVANTE. 7. TOURNÉZ LA SOUPAPE DE SECTIONNEMENT MANUELLE VERS LA GAUCHE À "ON". 8. FERMEZ LA PORTE VITRÉE. 9. RÉTABLISSEZ L'ALIMENTATION ÉLECTRIQUE AU FOYER. 10. ALLUMEZ LE BRÛLEUR PRINCIPAL.
---	--

TO TURN OFF GAS / INSTRUCTIONS POUR COUPER LE GAZ

<ol style="list-style-type: none"> 1. TURN OFF ALL ELECTRICAL POWER TO THE FIREPLACE IF SERVICE IS TO BE PERFORMED. 2. TURN MANUAL SHUTOFF VALVE CLOCKWISE TO OFF. DO NOT FORCE. 	<ol style="list-style-type: none"> 1. COUPEZ L'ALIMENTATION ÉLECTRIQUE AU FOYER SI UN TRAVAIL D'ENTRETIEN DOIT SE FAIRE. 2. TOURNÉZ LA SOUPAPE D'ARRÊT MANUELLE VERS LA DROITE À "OFF" NE FORCEZ PAS.
---	--

7.2 ANTI CONDENSATION SWITCH

This appliance has the option to go from an electronic intermittent pilot ignition (IPI) to a standing pilot for cold climates. The anti condensation control switch (standing pilot) is located on the left of the control panel. Using your finger, flip the switch up for standing pilot, or down for intermittent pilot ignition.

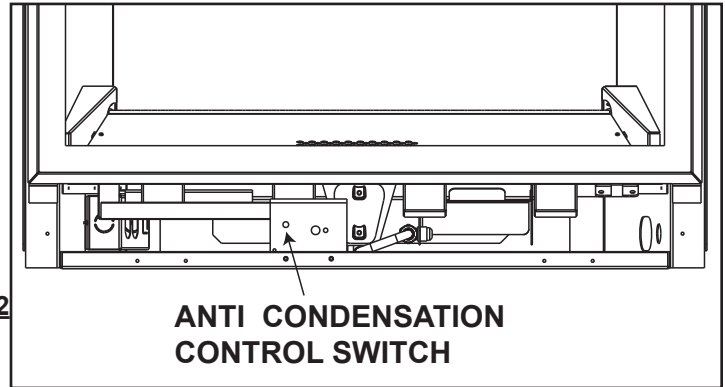

FIGURE 7.2

8.0 WIRING DIAGRAM

This appliance comes equipped with a battery back-up. Connect the battery holder to the wire harness before using the appliance. Place near the IPI board. (Batteries not included).

NOTE: If battery backup is used, it must be connected to a 6 volt battery pack.

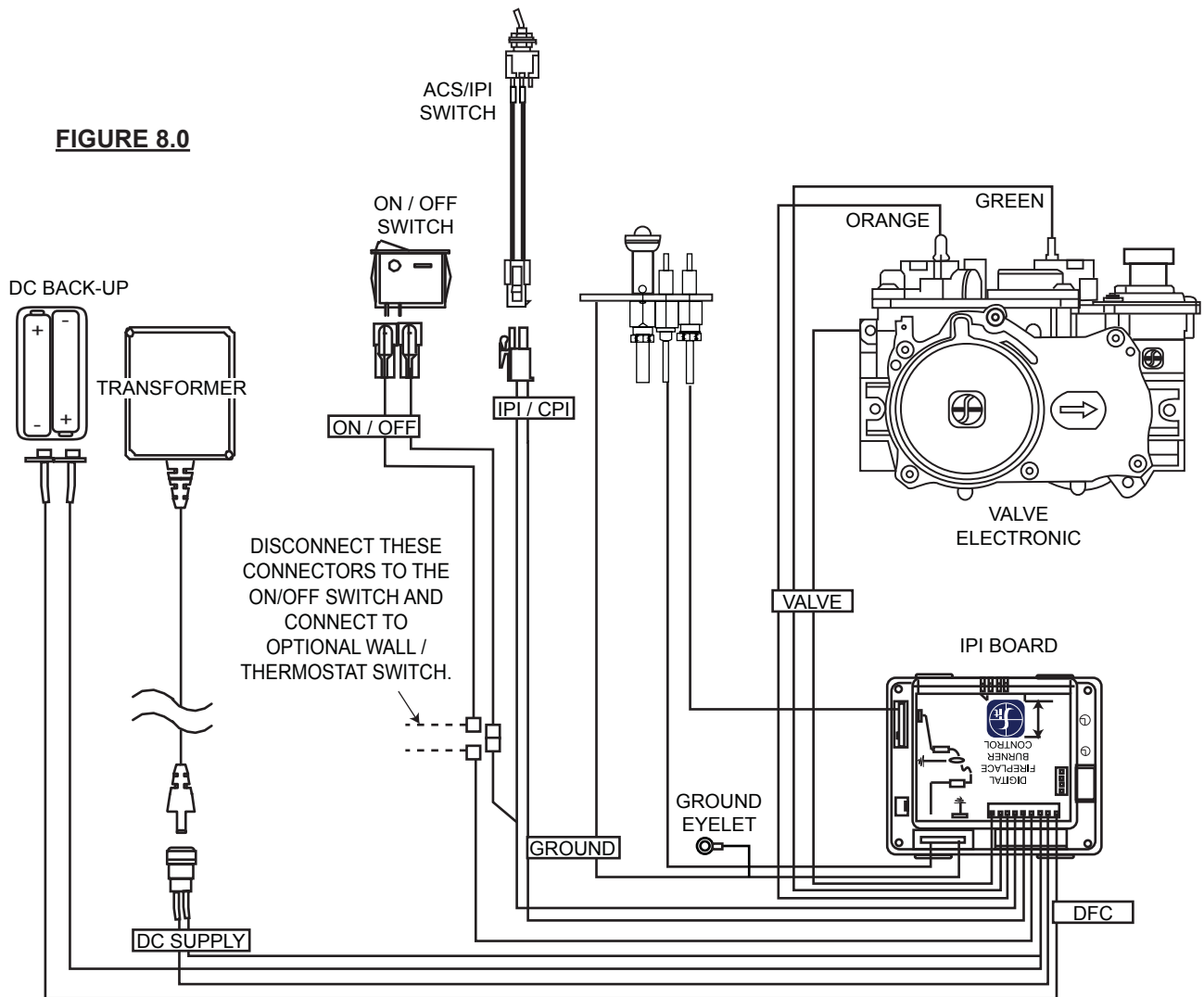
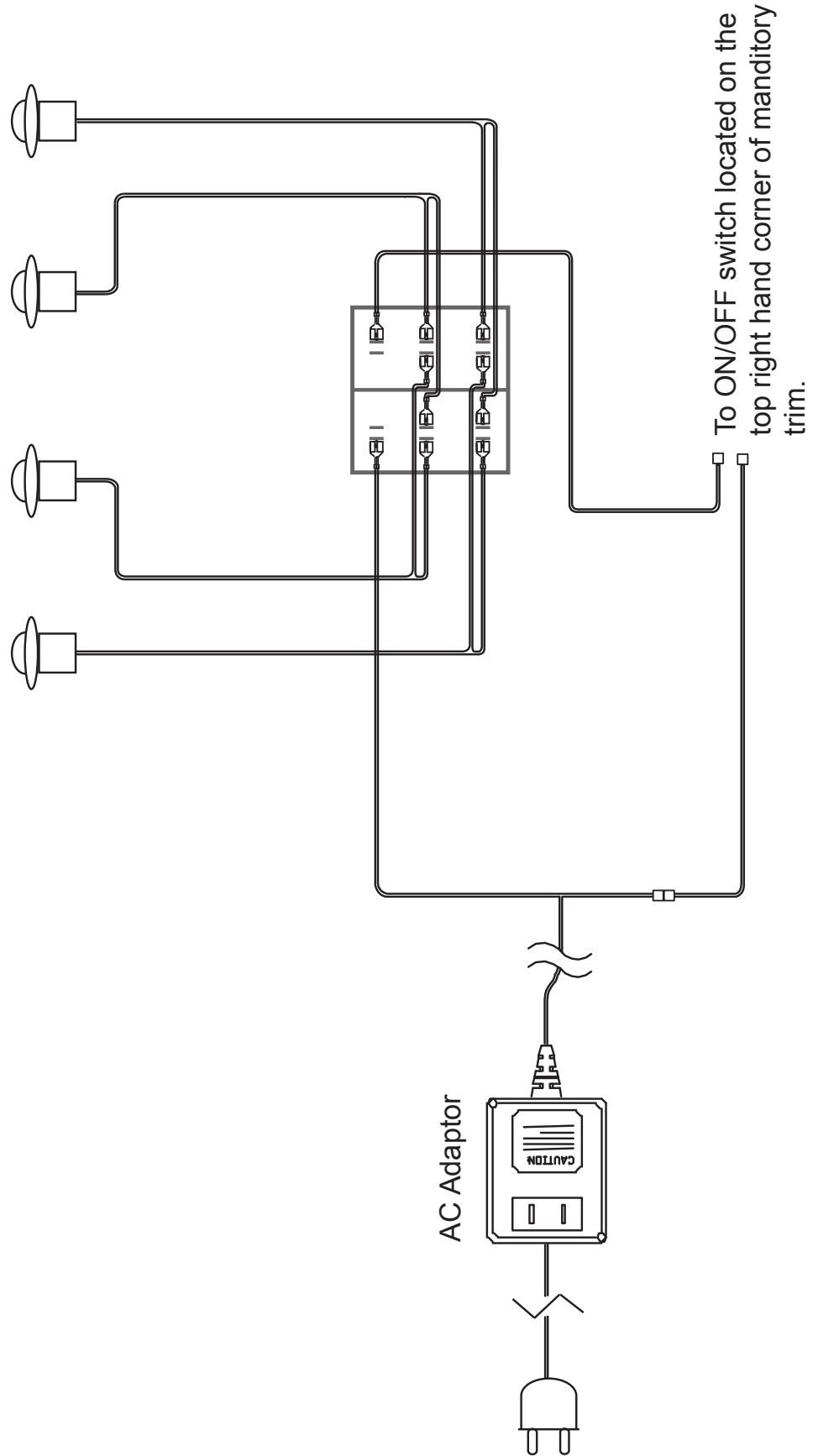

FIGURE 8.0

8.1 NIGHT LIGHT™ WIRING DIAGRAM

FIGURE 8.1



9.0 ADJUSTMENTS

9.1 PILOT BURNER ADJUSTMENT

Adjust the pilot screw to provide properly sized flame. Turn in a clockwise direction to reduce the gas flow.

FIGURE 9.1

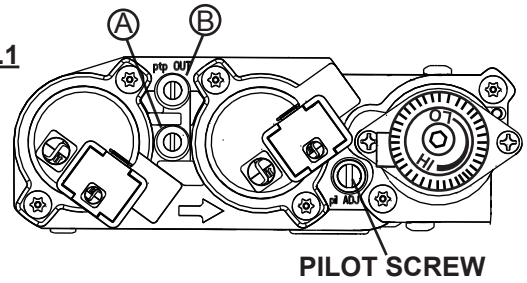

Check Pressure Readings:

Inlet pressure can be checked by turning screw (A) counter-clockwise 2 or 3 turns and then placing pressure gauge tubing over the test point. Gauge should read 7" (minimum 4.5") water column for natural gas or 13" (11" minimum) water column for propane. Check that main burner is operating on "HI".

Outlet pressure can be checked the same as above using screw (B). Gauge should read 3.5" water column for natural gas or 10" water column for propane. Check that main burner is operating on "HI".

AFTER TAKING PRESSURE READINGS, BE SURE TO TURN SCREWS CLOCKWISE FIRMLY TO RESEAL. DO NOT OVERTORQUE.

Leak test with a soap and water solution.

39.4

9.2 VENTURI ADJUSTMENT

! WARNING

THE FRONT OF THE APPLIANCE BECOMES VERY HOT DURING OPERATION. LET THE APPLIANCE COOL COMPLETELY BEFORE CONDUCTING SERVICE.

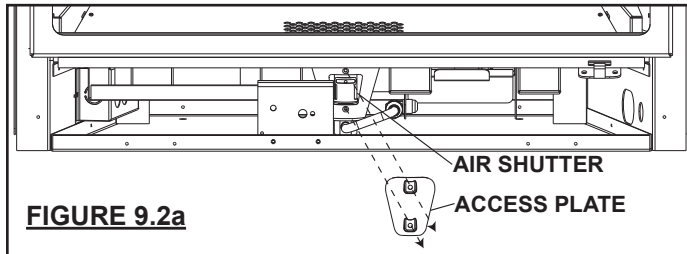

FIGURE 9.2a

This appliance has an air shutter that has been factory set open according to the chart below:

	CDI-30G
NG	0
LP	1/4"

Closing the air shutter will cause a more yellow flame, but can lead to carboning. Opening the air shutter will cause a more blue flame, but can cause flame lifting from the burner ports. The flame may not appear yellow immediately; allow 15 to 30 minutes for the final flame color to be established.

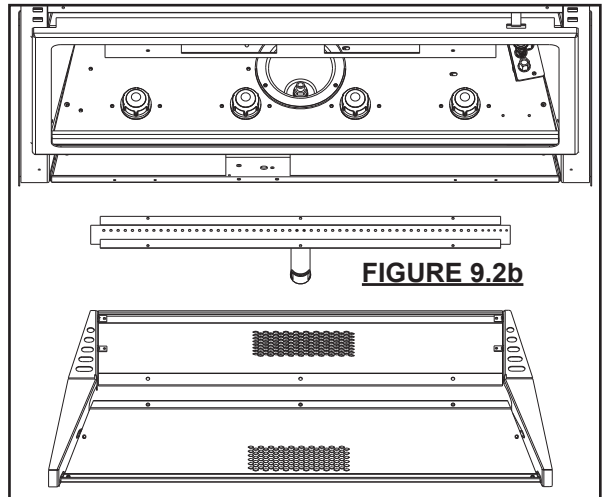

FIGURE 9.2b

AIR SHUTTER ADJUSTMENT MUST ONLY BE DONE BY A QUALIFIED INSTALLER!

Access plate and gasket must be re-installed after adjustment.

The alternate access is to remove the glass media, media tray and burner from the appliance and then adjust the air shutter. **NOTE:** When removing the media tray make sure the glass media are away from the center of the screen, exposing the burner, before lifting media tray out.

When replacing burner, absolutely no glass can be in cup surrounding the orifice. **HINT:** If glass falls into cup and surrounds the orifice, insert a clean bag into a vacuum cleaner and vacuum out glass media. Replacement glass media can be ordered from Wolf Steel Ltd.

9.3 FLAME ADJUSTMENT

Turn counter-clockwise to decrease flame height



Turn clockwise to increase flame height

FLAME ADJUSTMENT KNOB

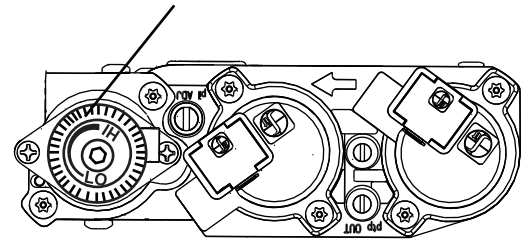

FIGURE 9.3

9.4 FLAME CHARACTERISTICS

It's important to periodically perform a visual check of the pilot and burner flames. Compare them to the illustrations provided. If any flames appear abnormal call a service person.

FIGURE 9.4a

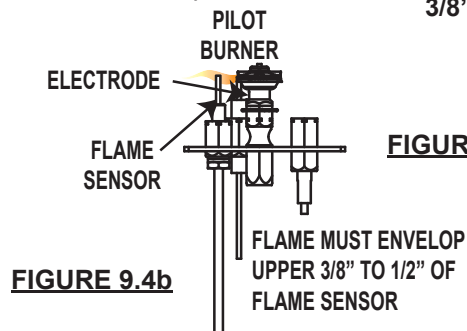
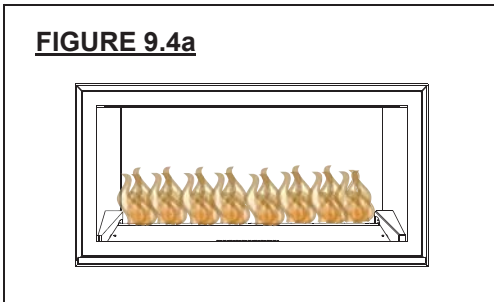
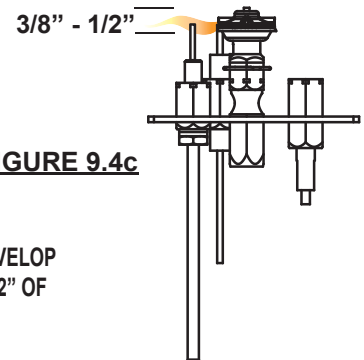

FIGURE 9.4b

FIGURE 9.4c



54.1

10.0 MAINTENANCE

! WARNING

TURN OFF THE GAS AND ELECTRICAL POWER BEFORE SERVICING THE APPLIANCE.

APPLIANCE MAY BE HOT, DO NOT SERVICE UNTIL APPLIANCE HAS COOLED.

DO NOT USE ABRASIVE CLEANERS.

CAUTION: Label all wires prior to disconnection when servicing controls. Wiring errors can cause improper and dangerous operation. Verify proper operation after servicing. This appliance and its venting system should be inspected before use and at least annually by a qualified service person. The appliance area must be kept clear and free of combustible materials, gasoline or other flammable vapors and liquids. The flow of combustion and ventilation air must not be obstructed.

1. In order to properly clean the burner and pilot assembly, remove the logs, rocks and/or glass to expose both assemblies.
2. Keep the control compartment, media, burner, air shutter opening and the area surrounding the logs clean by vacuuming or brushing, at least once a year.
3. Check to see that all burner ports are burning. Clean out any of the ports which may not be burning or are not burning properly.
4. Check to see that the pilot flame is large enough to engulf the flame sensor and/or thermocouple / thermopile as well as reaches the burner.
5. Replace the cleaned logs, rocks or glass. Failure to properly position the media may cause carboning which can be distributed in the surrounding living area.
6. Check to see that the main burner ignites completely on all openings when turned on. A 5 to 10 second total light-up period is satisfactory. If ignition takes longer, consult your local authorized dealer / distributor.
7. Check that the gasketing on the sides, top and bottom of the door is not broken or missing. Replace if necessary.
8. If for any reason the vent air intake system is disassembled, re-install and re-seal per the instructions provided for the initial installation.

40.1

11.0 REPLACEMENTS

Contact your dealer or the factory for questions concerning prices and policies on replacement parts. Normally all parts can be ordered through your Authorized dealer / distributor.

FOR WARRANTY REPLACEMENT PARTS, A PHOTOCOPY OF THE ORIGINAL INVOICE WILL BE REQUIRED TO HONOUR THE CLAIM.

When ordering replacement parts always give the following information:

- Model & Serial Number of appliance
- Installation date of appliance
- Part number
- Description of part
- Finish

*** IDENTIFIES ITEMS WHICH ARE NOT ILLUSTRATED. FOR FURTHER INFORMATION, CONTACT YOUR AUTHORIZED DEALER.**

WARNING

FAILURE TO POSITION THE PARTS IN ACCORDANCE WITH THIS MANUAL OR FAILURE TO USE ONLY PARTS SPECIFICALLY APPROVED WITH THIS APPLIANCE MAY RESULT IN PROPERTY DAMAGE OR PERSONAL INJURY.

41.1

COMPONENTS		
REF NO.	PART NO.	DESCRIPTION
1	GZ552	REPLACEMENT BLOWER
2	W725-0062	SIT VALVE - NG
2	W725-0063	SIT VALVE - LP
3	W455-0019	#43 NATURAL GAS BURNER ORIFICE
3	W455-0003	#54 PROPANE GAS BURNER ORIFICE
4	W010-1865	NATURAL GAS PILOT ASSEMBLY
4	W010-1866	PROPANE GAS PILOT ASSEMBLY
5*	W690-0002	THERMAL SENSING SWITCH
6*	W660-0009	BURNER ON/OFF SWITCH
7	W455-0069	NATURAL GAS PILOT INJECTOR
7	W455-0068	PROPANE GAS PILOT INJECTOR
8*	W385-0430	CONTINENTAL LOGO
9*	W562-0008	GLASS GASKET
10*	KB-35	VARIABLE SPEED SWITCH
11*	W010-1095	GLASS W/ GASKET
12	W010-1042	DOOR, GLASS & GASKET ASSEMBLY
13*	W100-0112	MAIN BURNER
14*	W190-0029	IPI BOARD
15*	W707-0010	TRANSFORMER
16*	W300-0102	CLEAR GLASS MEDIA
17*	W387-0011	5W LAMP ASSEMBLY
18*	W387-0009	HALOGEN LAMP 5W
TERMINAL KITS		
REF NO.	PART NO.	DESCRIPTION
19*	GDI-226	TERMINAL
VENT KITS		
REF NO.	PART NO.	DESCRIPTION
	1-2" & 1-3" DOUBLE PLY ALUMINUM LINER-INLET AND EXHAUST & 2-3" TO 2" REDUCER:	
20*	GDI-2320KT	VENT KIT 20FT
20*	GDI-2325KT	VENT KIT 25FT
20*	GDI-2335KT	VENT KIT 35FT
	2-3" DOUBLE PLY ALUMINUM LINER-INLET AND EXHAUST:	
21*	GDI-320KT	VENT KIT 20FT
21*	GDI-325KT	VENT KIT 25 FT
21*	GDI-335KT	VENT KIT 35 FT

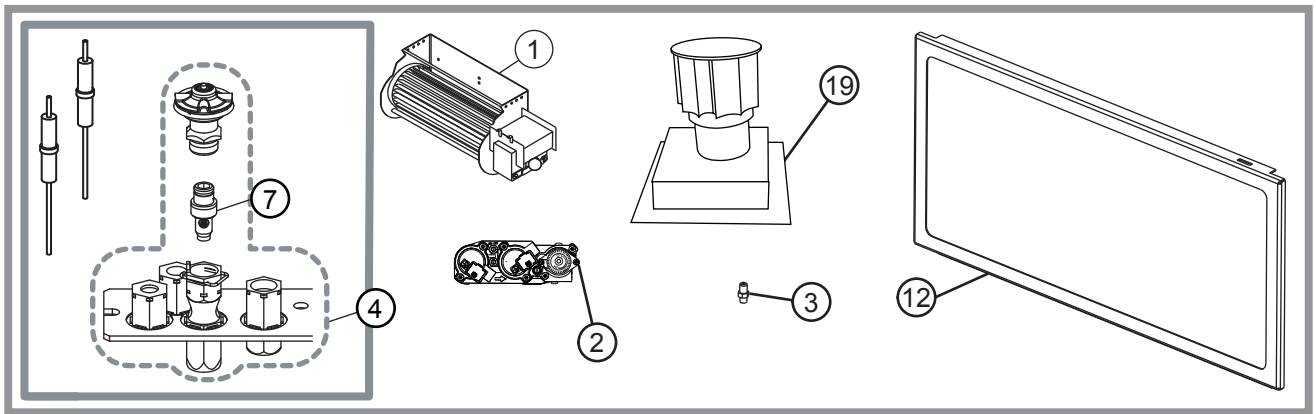

ACCESSORIES

REF NO.	PART NO.	DESCRIPTION
1*	F40	ON / OFF REMOTE
1*	F50	THERMOSTAT REMOTE
2*	GD-660	REMOTE WALL SWITCH WITH 20" WIRE
3*	W660-0026	TIMER, BATTERY OPERATED
4*	GI-RB	RISER BOX - PAINTED BLACK
5*	W175-0322	CONVERSION KIT - LP-NG
5*	W175-0323	CONVERSION KIT - NG-LP

12.0 TROUBLE SHOOTING

! WARNING

ALWAYS LIGHT THE PILOT WHETHER FOR THE FIRST TIME OR IF THE GAS SUPPLY HAS RAN OUT, WITH THE GLASS DOOR OPEN OR REMOVED.

TURN OFF THE GAS AND ELECTRICAL POWER BEFORE SERVICING THE APPLIANCE.

APPLIANCE MAY BE HOT, DO NOT SERVICE UNTIL APPLIANCE HAS COOLED.

DO NOT USE ABRASIVE CLEANERS.

SYMPTOM	PROBLEM	TEST SOLUTION
Pilot will not light. Makes noise with no spark at pilot burner.	Wiring.	- Verify the wire for the sensor and the wire for the ignitor are connected to the correct terminals (not reversed) on the module. NOTE: Sensor has 3/16" connection and ignitor has 1/8" connection.
	Loose connection.	- Verify no loose connections, electrical shorts in the wiring or ground out to any metal object.
	Module.	- Turn the ON/OFF switch to the "OFF" position. Remove the igniter wire from the module. Place the ON/OFF switch to the "ON" position. Hold a grounded wire about 3/16" away from the ignitor (spark) terminal on the module. If no spark the ignitor terminal module must be replaced. If there is a spark the ignitor terminal is fine. Inspect pilot assembly for a shorted wire or cracked insulator around the electrode.
	Igniter Spark gap is incorrect.	- Spark gap of the ignitor to the pilot should be 1/8".
	Transformer.	- Verify the transformer is installed and plugged into the module. Check voltage of the transformer under load at the spade connections on the module with the ON/OFF switch in the "ON" position. Acceptable readings of a good transformer are between 6.2 and 7.0 volts A.C.
	Battery backup	- Check batteries.
	A shorted or loose Connection.	- Remove and reinstall the wiring harness that plugs into the module. Remove and verify continuity of each wire in wiring harness.
Pilot sparks but will not light.	Improper switch wiring.	- Troubleshoot the system with the simplest ON/OFF switch.
	Module is not grounded.	- Verify the value and pilot assemblies are properly grounded to the metal chassis of the appliance or log set.
	Gas supply.	- Verify that the incoming gas line ball valve is "Open". Verify that the inlet pressure reading is within acceptable limits, inlet pressures must not exceed 14" W.C.
	Out of propane gas.	- Fill the tank.

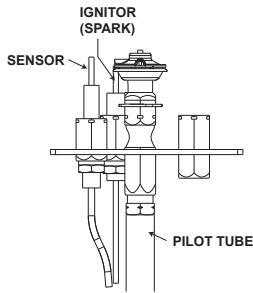

SYMPTOM	PROBLEM	TEST SOLUTION
Carbon is being deposited on glass, logs, rocks, media or combustion chamber surfaces.	Air shutter has become blocked.	- Ensure air shutter opening is free of lint or other obstructions.
	Flame is impinging on the glass, logs, rocks, media or combustion chamber.	- Check that the glass, logs, rocks or media are correctly positioned. - Open air shutter to increase the primary air. - Check the input rate: check the manifold pressure and orifice size as specified by the rating plate values. - Check that the door gasketing is not broken or missing and that the seal is tight. - Check that both vent liners are free of holes and well sealed at all joints. - Check that minimum rise per foot has been adhered to for any horizontal venting.
Continues to spark and pilot lights, but main burner will not light.	Short or loose connection in sensor rod.	- Verify all connections. Verify the connections from the pilot assembly are tight; also verify these connections are not grounding out to any metal.
	Poor flame rectification or contaminated sensor rod.	- Verify the flame is engulfing the sensor rod. This will increase the flame rectification. Verify correct pilot orifice is installed and inlet gas specifications to manual. (Remember, the flame carries the rectification current, not the gas. If the flame lifts from pilot hood, the circuit is broken. A wrong orifice or too high of an inlet pressure can cause the pilot flame to lift.) The sensor rod may need cleaning.
	Poor grounding between pilot assembly and gas valve.	- Verify that the wire harness is firmly connected to module. Verify that the ceramic insulator around the sensor rod is not cracked, damaged, or loose. Verify the connection from the sensor rod to the sensor wire.
	Damaged pilot or dirty sensor rod.	- Clean sensor rod with an emery cloth to remove any contamination that may have accumulated on the sensor rod. Verify continuity with multimeter with ohms set at the lowest range.
Pilot lights Stops sparking / pilot remains lit but burner will not turn on.	Wiring / Connection.	- Inspect all wires, ensure good tight connections. Verify that all wiring is installed exactly as specified.
	Wiring harness.	- Inspect the wiring harness, and verify the harness is tightly connected to the module. Verify that all wires are connected in the right order. See "WIRING DIAGRAM" section.
Exhaust fumes smelled in room, headaches.	Appliance is spilling.	- Check all seals. - Check if exhaust is re-entering through an open door or window.

42.7_2

SYMPTOM	PROBLEM	TEST SOLUTION
White / grey film forms.	Sulphur from fuel is being deposited on glass, logs or combustion chamber surfaces.	<ul style="list-style-type: none"> - Clean the glass with a recommended gas appliance glass cleaner. DO NOT CLEAN GLASS WHEN HOT. - If deposits are not cleaned off regularly, the glass may become permanently marked.
Flames are very aggressive.	Door is ajar.	- Tighten door clamps.
	Venting action is too great.	- Restrict vent exit with restrictor plate. See "RESTRICTING VENTS" section.
Main burner flame is a blue, lazy, transparent flame.	Blockage in vent.	- Remove blockage. In really cold conditions, ice buildup may occur on the terminal and should be removed.
	Compromised venting.	- Check venting system parameters (seal, length, rise, etc.).
	GLASS EMBERS ONLY: Too many glass embers.	- Re-distribute glass embers so that only a single layer is over top of the burner tube.
Main burner goes out: pilot goes out.	Vent recirculation.	- Check joint seals and installation.

42.7_3

13.0 WARRANTY

CONTINENTAL® products are manufactured under the strict Standard of the world recognized ISO 9001 : 2008 Quality Assurance Certificate.

CONTINENTAL® products are designed with superior components and materials assembled by trained craftsmen who take great pride in their work. The burner and valve assembly are leak and test-fired at a quality test station. The complete heater is again thoroughly inspected by a qualified technician before packaging to ensure that you, the customer, receives the quality product that you expect from CONTINENTAL®.

CONTINENTAL® GAS FIREPLACE PRESIDENT'S LIFETIME LIMITED WARRANTY

The following materials and workmanship in your new CONTINENTAL® gas heater are warranted against defects for as long as you own the heater. This covers: combustion chamber, heat exchanger, stainless steel burner, phazer™ logs and embers, rocks, ceramic glass (thermal breakage only), gold plated parts against tarnishing, porcelainized enameled components and aluminum extrusion trims.*

Electrical (110V and millivolt) components and wearable parts such as blowers, gas valves, thermal switch, switches, wiring, remote controls, ignitor, gasketing, and pilot assembly are covered and CONTINENTAL® will provide replacement parts free of charge during the first year of the limited warranty.*

Any labour related to warranty repair is not covered.

* Construction of models vary. Warranty applies only to components included with your specific heater.

CONDITIONS AND LIMITATIONS

CONTINENTAL® warrants its products against manufacturing defects to the original purchaser only. Registering your warranty is not necessary. Simply provide your proof of purchase along with the model and serial number to make a warranty claim. CONTINENTAL® reserves the right to have its representative inspect any product or part thereof prior to honouring any warranty claim. Provided that the purchase was made through an authorized CONTINENTAL® dealer your heater is subject to the following conditions and limitations:

This factory warranty is non-transferable and may not be extended whatsoever by any of our representatives.

The gas heater must be installed by a licensed, authorized service technician or contractor. Installation must be done in accordance with the installation instructions included with the product and all local and national building and fire codes. This limited warranty does not cover damages caused by misuse, lack of maintenance, accident, alterations, abuse or neglect and parts installed from other manufacturers will nullify this warranty.

This limited warranty further does not cover any scratches, dents, corrosion or discoloring caused by excessive heat, abrasive and chemical cleaners nor chipping on porcelain enamel parts, mechanical breakage of PHAZER™ logs and embers.

CONTINENTAL® warrants its stainless steel burners against defects in workmanship and material for life, subject to the following conditions: During the first 10 years CONTINENTAL® will replace or repair the defective parts at our option free of charge. From 10 years to life, CONTINENTAL® will provide replacement burners at 50% of the current retail price.

In the first year only, this warranty extends to the repair or replacement of warranted parts which are defective in material or workmanship provided that the product has been operated in accordance with the operation instructions and under normal conditions. After the first year, with respect to this President's Lifetime Limited Warranty, CONTINENTAL® may, at its discretion, fully discharge all obligations with respect to this warranty by refunding to the original warranted purchaser the wholesale price of any warranted but defective part(s).

CONTINENTAL® will not be responsible for installation, labour or any other expenses related to the reinstallation of a warranted part and such expenses are not covered by this warranty.

Notwithstanding any provisions contained in the President's Lifetime Limited Warranty, CONTINENTAL'S responsibility under this warranty is defined as above and it shall not in any event extend to any incidental, consequential or indirect damages.

This warranty defines the obligations and liability of CONTINENTAL® with respect to the CONTINENTAL® gas heater and any other warranties expressed or implied with respect to this product, its components or accessories are excluded.

CONTINENTAL® neither assumes, nor authorizes any third party to assume, on its behalf, any other liabilities with respect to the sale of this product.

CONTINENTAL® will not be responsible for: over-firing, downdrafts, spillage caused by environmental conditions such as rooftops, buildings, nearby trees, hills, mountains, inadequate vents or ventilation, excessive venting configurations, insufficient makeup air, or negative air pressures which may or may not be caused by mechanical systems such as exhaust fans, furnaces, clothes dryers, etc. Any damages to heater, combustion chamber, heat exchanger, brass trim or other components due to water, weather damage, long periods of dampness, condensation, damaging chemicals or cleaners will not be the responsibility of CONTINENTAL®.

ALL SPECIFICATIONS AND DESIGNS ARE SUBJECT TO CHANGE WITHOUT PRIOR NOTICE DUT TO ON-GOING PRODUCT IMPROVEMENTS. CONTINENTAL® IS A REGISTERED TRADEMARK OF WOLF STEEL LTD. PATENTS U.S. 5.303.693.801 - CAN. 2.073.411, 2.082.915 © WOLF STEEL LTD.

