

**INSTALLER: THESE INSTRUCTIONS MUST BE CONVEYED TO AND REMAIN WITH THE HOMEOWNER.**

CERTIFIED UNDER U.S. ENVIRONMENTAL PROTECTION AGENCY (E.P.A.) JULY 1990 AND THE OREGON DEPARTMENT OF ENVIRONMENTAL QUALITY (D.E.Q.) PARTICULATE EMISSION STANDARDS BY E.E.M.C. THESE STOVES HAVE BEEN TESTED AND LISTED BY INTERTEK TESTING SERVICES TO STANDARDS: CSA B366.2, ULCS627, ULC S628, UL 1482. MODEL C1100 HAS BEEN TESTED AND LISTED FOR INSTALLATION IN MOBILE HOMES.



## INSTALLATION AND OPERATION INSTRUCTIONS FOR HI-TECH LISTED SOLID FUEL BURNING STOVES AND INSERTS

FREE STANDING MODELS EPA C1100, C1100L, C1100C, C1400, C1400L & C1900  
INSERT MODELS EPI C1101, C1401

### **WARNING:**

Please read this entire manual before you install and use your new room heater. Failure to follow instructions may result in property damage, bodily injury, or even death.

If this unit is not properly installed, a house fire may result.

### **FOR YOUR SAFETY**

Follow the installation directions. This unit can be very hot when burning. Combustible materials such as firewood, wet clothing, etc. placed too close can catch fire. Children and pets must be kept from touching the unit when it is hot. The chimney must be sound and free of cracks. Before installing your unit, contact the local building or fire authority and follow their guidelines.

The door must be kept closed during operation to prevent smoke, embers from entering the room. Burn wood directly on firebricks. Do not use a grate or elevate the fire. At least 14 square inches (90 sq.cm.) of outside air must be admitted to the room or directly to the unit through a 4 inch (10cm.) diameter pipe. This unit is designed to burn natural wood only. Higher efficiencies and lower emissions generally result when burning air dried seasoned hardwoods, as compared to softwoods or to green or freshly cut hardwoods. Do not start a fire with chemicals or fluids such as gasoline, engine oil, etc. Do not burn treated wood, coal, charcoal, coloured paper, cardboard, solvents or garbage which tend to produce more pollution than wood. Do not let the unit become hot enough for any part to glow red.

KEEP THE STOVE TOP TEMPERATURE BELOW 700°F (371°C). Attempts to achieve heat output rates that exceed design specifications can result in steel distortion and damage.



Wolf Steel Ltd., 24 Napoleon Rd., Barrie, ON L4M 4Y8 Canada • (705)721-1212 • fax(705)722-6031

[www.continentalfireplaces.com](http://www.continentalfireplaces.com) • [ask@continentalfire.com](mailto:ask@continentalfire.com)

# TABLE of CONTENTS

## PG 2-4 INTRODUCTION

Warranty  
General Information  
Care of Plated & Enamelled Parts  
Care of Glass

## 5-6 INSTALLATION

Installing the Legs  
Alcove Installation  
Stove Installation  
Chimney Connection  
Adding Chimney Sections  
Outside Air  
Wall Pass-through

## 6-7 MOBILE HOME INSTALLATION

Venting  
Outside Air

## 7-8 FIREPLACE INSERT INSTALLATION

Prior to Installation  
Installation into a Masonry Fireplace  
Installation into a Factory Built Fireplace

## 8-9 OPTIONAL FAN INSTALLATIONS

Stove Models  
Insert Models

## 10-11 FINISHING

Brick Installation  
Ornamental Trivet Installation  
Door and Handles Installation  
Pedestal Trim Installation  
Optional Ash Drawer Kit

## 11-13 OPERATION

Achieving Proper Draft  
Fire Extinguishers and Smoke Detectors  
Fuel Loading and Burn Cycle  
Flash Fire  
Extended Fire  
Smoking  
Ash Removal Procedures

## 13-14 MAINTENANCE

Creosote Formation and Removal  
Runaway or Chimney Fire  
Gasket Replacement  
Door Removal

## 14 WOOD PILE MAINTENANCE & SERVICE HISTORY

## 15-16 REPLACEMENTS

Ordering Replacement Parts  
Replacement Parts  
Accessories

**PLEASE RETAIN THIS MANUAL FOR FUTURE REFERENCE**

SPECIFICATIONS	MODEL C1100, C1100C& C1100L	MODEL C1101 (INSERT)	MODEL C1400 & C1400L	MODEL C1401 (INSERT)	MODEL C1900
WIDTH	25 1/2 in. (65 cm)	28 in. (71 cm)	25 1/2 in. (65 cm)	25 1/2 in. (65 cm)	25 1/2 in. (80 cm)
DEPTH DEPTH BEHIND FLASHING	22 1/2 in. (57 cm)	24 in. (61 cm) 16 1/2 to 21 in. (42 to 54 cm)	27 in. (69 cm)	27 in. (69 cm) 14 1/2 in. (37 cm)	31 1/2 in. (65 cm)
FLUE CENTERLINE TO REAR	6 1/2" (16.51 cm)	11" (27.94 cm)	7 1/2" (19.05 cm)	5 1/2" (13.97 cm)	7 1/2" (19.05 cm)
FLUE CENTERLINE TO SIDE	12 3/4" (32.39 cm)	14" (35.56 cm)	12 3/4" (32.39 cm)	12 3/4" (32.39 cm)	12 3/4" (32.39 cm)
HEIGHT	PEDESTAL MODEL CAST MODEL LEG MODEL	33 1/4 in. (84cm) 28 1/2 in. (72cm) 32 in. (81cm)	21 1/4 in. (55cm)	33 1/4 in. (84cm) 32 in. (81cm)	33 1/4 in. (84cm)
CHAMBER (D.W.H.)	13-1/2x18x12in. (34 x 46 x 31 cm)	13-1/2x18x12in. (34 x 46 x 31 cm)	18 x 18 x 12 in. (46 x 46 x 31 cm)	18 x 18 x 12 in. (46 x 46 x 31 cm)	22 1/2 x 18 x 12 3/4 in. (57 x 46 x 32 cm)
CAPACITY	1.7 ft <sup>3</sup> (0.05 m <sup>3</sup> )	1.7 ft <sup>3</sup> (0.05 m <sup>3</sup> )	2.25 ft <sup>3</sup> (0.06 m <sup>3</sup> )	2.25 ft <sup>3</sup> (0.06 m <sup>3</sup> )	3.0 ft <sup>3</sup> (0.08 m <sup>3</sup> )
APPROX. AREA HEATED*	600-1200 ft <sup>2</sup> (56-112 m <sup>2</sup> )	600-1200 ft <sup>2</sup> (56-112 m <sup>2</sup> )	1000-1800 ft <sup>2</sup> (92-167 m <sup>2</sup> )	1000-1800 ft <sup>2</sup> (92-167 m <sup>2</sup> )	1500-2000 ft <sup>2</sup> (139-186 m <sup>2</sup> )
HEAT OUTPUT (HIGH BURN)**	50,000 BTU	50,000 BTU	60,000 BTU	60,000 BTU	70,000 BTU
DURATION LOW FIRE*	7 HOURS	7 HOURS	9 HOURS	9 HOURS	12 HOURS
WEIGHT W/O BRICKS	215 lbs (97.5 kg)	185 lbs (83.9 kg)	250 lbs (113 kg)	250 lbs (113 kg)	285 lbs (129 kg)
WEIGHT OF BRICKS	110 lbs (50 kg)	120 lbs (54.4 kg)	145 lbs (66 kg)	145 lbs (66 kg)	114 lbs (52 kg)

\*FIGURES WILL VARY CONSIDERABLY WITH INDIVIDUAL CONDITIONS.

\*\* WOLF STEEL LTD. ESTIMATED REALISTIC BTU/H WITH HARDWOOD LOGS AND REGULAR REFUELING.

**NOTE:** Changes, other than editorial, are denoted by a vertical line in the margin.

*CONTINENTAL wood fireplaces are manufactured under the strict Standard of the World Recognized ISO9002 Quality Assurance Certificate.*

*CONTINENTAL products are designed with superior components and materials, assembled by trained craftsmen who take great pride in their work. The complete fireplace is thoroughly inspected by a qualified technician before packaging to ensure that you, the customer, receives the quality product that you expect from CONTINENTAL.*

### **CONTINENTAL WOOD FIREPLACE PRESIDENT'S LIFETIME LIMITED WARRANTY**

***The following materials and workmanship in your new CONTINENTAL wood fireplace are warranted against defects for as long as you own the fireplace. This covers: combustion chamber, heat exchanger, stainless steel baffle retainer, ceramic glass (thermal breakage only), gold plated parts against tarnishing, porcelainized enamelled components, aluminum extrusion, trims, ashdrawer, and cast iron castings.***

***Electrical (110V) components and wearable parts such as blowers, thermal switch, switches, wiring, firebrick, gasketing, and high temperature paint are covered and WOLF STEEL LTD. will provide replacement parts free of charge during the first year of the limited warranty. Any labour related to the warranty repair is not covered.***

### **CONDITIONS AND LIMITATIONS**

WOLF STEEL LTD. warrants its products against manufacturing defects to the original purchaser only -- i.e., the individual or legal entity (registered customer) whose name appears on the warranty registration card filed with WOLF STEEL LTD. -- provided that the purchase was made through an authorized CONTINENTAL dealer and is subject to the following conditions and limitations:

This factory warranty is nontransferable and may not be extended whatsoever by any of our representatives.

The wood fireplace must be installed by a licenced, authorized service technician or contractor. Installation must be done in accordance with the installation instructions included with the product and all local and national building and fire codes.

This limited warranty does not cover damages caused by misuse, lack of maintenance, accident, alterations, abuse or neglect and parts installed from other manufacturers will nullify this warranty.

This limited warranty further does not cover any scratches, dents, corrosion or discolouring caused by excessive heat, abrasive and chemical cleaners nor chipping on porcelain enamel parts, nor any venting components used in the installation of the fireplace.

In the first year only, this warranty extends to the repair or replacement of warranted parts which are defective in material or workmanship provided that the product has been operated in accordance with the operation instructions and under normal conditions.

After the first year, with respect to the President's Limited Five Year Warranty, WOLF STEEL LTD. may, at its discretion, fully discharge all obligations with respect to this warranty by refunding to the original warranted purchaser the wholesale price of any warranted but defective part(s).

After the first year, WOLF STEEL LTD. will not be responsible for installation, labour or any other costs or expenses related to the reinstallation of a warranted part, and such expenses are not covered by this warranty.

Notwithstanding any provisions contained in the President's Limited Five Year Warranty, WOLF STEEL LTD.'S responsibility under this warranty is defined as above and it shall not in any event extend to any incidental, consequential or indirect damages.

This warranty defines the obligations and liability of WOLF STEEL LTD. with respect to the CONTINENTAL wood fireplace and any other warranties expressed or implied with respect to this product, its components or accessories are excluded.

WOLF STEEL LTD. neither assumes, nor authorizes any third party to assume, on its behalf, any other liabilities with respect to the sale of this product. WOLF STEEL LTD. will not be responsible for: over-firing, downdrafts, spillage caused by environmental conditions such as rooftops, buildings, nearby trees, hills, mountains, inadequate vents or ventilation, excessive venting configurations, insufficient makeup air, or negative air pressures which may or may not be caused by mechanical systems such as exhaust fans, furnaces, clothes dryers, etc.

Any damages to fireplace, combustion chamber, heat exchanger, brass trim or other component due to water, weather damage, long periods of dampness, condensation, damaging chemicals or cleaners will not be the responsibility of WOLF STEEL LTD.

The bill of sale or copy will be required together with a serial number and a model number when making any warranty claims from your authorized dealer. The warranty registration card must be returned within fourteen days to register the warranty.

WOLF STEEL LTD. reserves the right to have its representative inspect any product or part thereof prior to honouring any warranty claim.

## GENERAL INFORMATION

Except for their different depths, models C1100, C1400, C1900 and the fireplace inserts C1101 and C1401 are identical and use the same burning principles. They were specifically designed over many months of research to meet the 1990 U.S.A. EPA particulate emission standards and have been extensively tested in Canadian and American laboratories. This system is the most efficient, simple and trouble free we know and works as follows:

Combustion air enters through two holes in the bottom covered by a single draft control. Air from the front hole goes up on either side of the door into a preheating airwash located across the top and then down the window to feed the fire and also to ensure that the glass remains clean. Air from this hole also feeds directly into the combustion chamber at hearth level. Secondary air from the rear hole travels up the back in the secondary air housing to the manifold located at the top and shoots out laterally to oxidize the gases below the smoke exit.

The combustion chamber is lined with high temperature firebrick on 2 sides, the back and across the bottom, with a layer of fibre baffles at the top to maintain a high temperature in the combustion chamber so that gases mixing with the preheated air from the secondary air manifold tube are easily ignited and burned. Indeed, it is fascinating to watch blue flames flickering much of the time from the manifold. The stove sides and back are shielded to direct the heat upwards and forwards into the room.

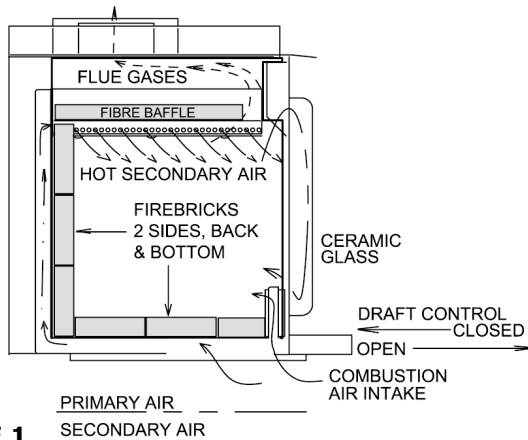

**FIGURE 1**

Be sure to provide sufficient combustion air. There are many other appliances in your home competing for air such as: a kitchen range hood, forced air heating devices or a bathroom exhaust fan.

**Do not connect this unit to a chimney flue serving another appliance.**

Expansion / contraction noises during heating up and cooling down cycles are normal and to be expected.

After extended periods of non-operation such as following a vacation or a warm weather season, the fireplace may emit a slight odour for a few hours. This is caused by dust particles in the firebox burning off. Open a window to sufficiently ventilate the room.

### **CALIFORNIA PROP 65 WARNING:**

**Use of this product may produce smoke which contains chemicals known to the State of California to cause cancer, birth defects, or other reproductive harm.**

## PEDESTAL MODELS ONLY

If the outside air feature of the stove is utilized, you should never experience a shortage of combustion air. If you choose not to utilize outside air and experience draft or smoking problems, you may need to open a door or window.

**WARNING: Burning your unit with the ash dump door open or ajar creates a fire hazard that may result in discoloration to the gold plated door, internal damage to the stove or a house and/or chimney fire.**

To ensure that the ash dump door is tightly closed, allow the door to snap shut dislodging anything (ashes or pieces of coal) that may be stuck in the opening.

## LEG MODELS ONLY

If you experience smoking problems, you may need to open a door, a window or otherwise provide some method of supplying combustion air to the unit.

## CARE OF ALL PLATED AND ENAMELED PARTS

Do not use abrasive cleaners to clean these parts. Buff lightly with a clean dry cloth.

Prolonged high temperature burning with the door ajar may cause a permanent rainbowing effect on the lower edge of a gold plated door.

Porcelain enamel components must be handled with care. The baked-on finish is "glass". If struck, it will chip. Touch-up paint is available through your Continental dealer.

## CARE OF GLASS

If the glass is not kept clean permanent discoloration and / or blemishes may result. Normally a hot fire will clean the glass. The most common reasons for dirty glass include; not using sufficient fuel to get the stove thoroughly hot, using green or wet wood, closing the draft so far that there is insufficient air for complete combustion. If it is necessary to clean the glass, use a soft cloth with a nonabrasive cleaner.

### **DO NOT CLEAN GLASS WHEN HOT!**

The glass is very strong but do not let burning fuel rest against it and always close the door gently. If the glass should ever crack while the fire is burning, do not open the door until the fire is out and do not operate the stove again until the glass has been replaced with a new 5mm thick plate of ceramic glass, available from your Continental / Wolf Steel Ltd. dealer.

### **DO NOT SUBSTITUTE MATERIALS.**

**TO REMOVE THE GLASS:** When the unit is cool, open the door and remove the screws and brackets holding the glass in place. Remove all broken glass. Wrap the edges of the new glass with a U-shaped strip of fiberglass gasket, covering 1/4" on each side. Place the glass with the fiberglass gasket in position and replace the brackets and screws. When finished, you should be able to move the glass slightly, horizontally and vertically.

# STOVE INSTALLATION

## INSTALLING THE LEGS

**To avoid being damaged during shipping, the stove has been bolted to the pallet and must be unbolted before the stove can be installed.**

**FIGURE 2A**

1. Remove the 4 nuts and washers from the underside of the pallet.
2. Lift the stove up and away from the pallet to clear the threaded studs sticking through the pallet. Place the stove on its back onto a protective surface such as a carpet or blanket to avoid scratches during leg installation.

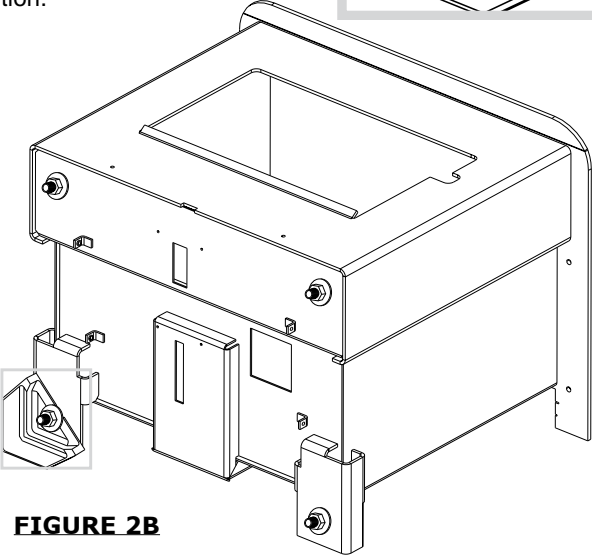
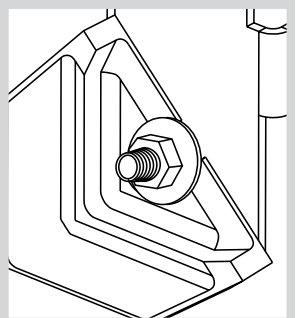
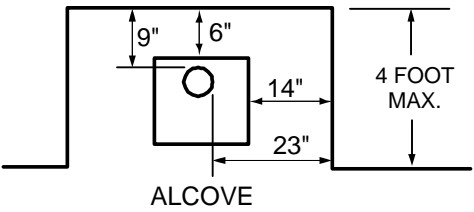

**FIGURE 2B**

3. Remove the four additional nuts from each of the four studs.
4. Use four of the nuts and washers removed above to install the legs as illustrated in **FIGURES 2a & 2b**.
5. Lift the stove up and gently set down on all four legs. Do not pivot unit up on its legs, as this could result in damage to the legs.

## ALCOVE INSTALLATION

Model C1100 only may be installed, using a listed double wall connector, such as **Security DL6** in Canada, the **Simpson Duravent Plus DVL** in the USA or an equivalent double wall connector, into an alcove having a depth of no more than 4 feet and a height of at least 7 feet. The minimum clearances are as shown in **FIGURE 3**.



**FIGURE 3**

## STOVE INSTALLATION

If the stove is to be installed on a combustible floor, it must be placed on a approved non-combustible hearth pad, that extends 8" (200mm) beyond the stove sides and back, and 18" (455mm) to the front.

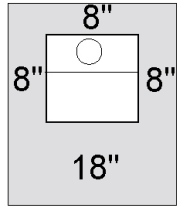

**FIGURE 4A**

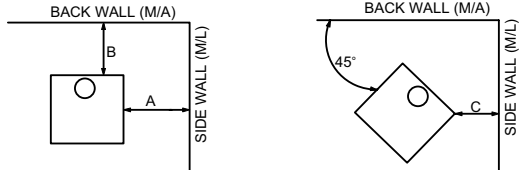

**FIGURE 4B**

SINGLE WALL CHIMNEY CONNECTOR*			
	C1100/C1100L	C1400/C1400L	C1900
<b>A</b>	12" (305mm)	12" (305mm)	22" (560mm)
<b>B</b>	10" (254mm)	12" (305mm)	12" (305mm)
<b>C</b>	6" (152mm)	6" (152mm)	8" (205mm)

DOUBLE WALL CHIMNEY CONNECTOR			
	C1100/C1100L	C1400/C1400L	C1900
<b>A</b>	10" (254mm)	10" (254mm)	22" (560mm)
<b>B</b>	6" (152mm)	6" (152mm)	12" (305mm)
<b>C</b>	2" (50mm)	4" (102mm)	8" (205mm)

\* CLEARANCES CAN BE REDUCED WITH SHIELDING ACCEPTABLE TO LOCAL AUTHORITIES. REDUCED INSTALLATION MUST COMPLY WITH NFPA 211 or CAN/CSA-B365

## CHIMNEY CONNECTION

A 6" diameter single wall stove pipe, used to connect the stove to the chimney, must be installed with the crimped end toward the stove. This will ensure that the moisture which condenses from the burning wood will flow back into the fire chamber. Each joint in the stove pipe must be secured with at least three sheet metal screws.

- This room heater must be connected to:
- 1) A chimney complying with the requirements for Type HT chimneys in the Standard for Chimneys, Factory-Built, Residential Type and Building Heating Appliance UL 103, or
  - 2) A code-approved masonry chimney with a flue liner.

Vent the stove into a masonry chimney or an approved, insulated solid-fuel stainless-steel chimney with as short and straight a length of six-inch (150mm) diameter smoke pipe as possible. Connection to a masonry chimney must be by a metal or masonry thimble cemented in place.

An insulated stainless steel chimney must be supported at the ceiling or roof and its installation must comply with its manufacturer's instructions.

**THE TOTAL HORIZONTAL VENT LENGTH SHOULD NOT EXCEED 40% OF THE CHIMNEY HEIGHT ABOVE THE STOVE.**

**All horizontal smoke pipe must slope slightly upwards a minimum of 1/4" per foot (6mm/0.3m) and all connections must be tight and secured by three sheet metal screws equally spaced.**

**An uninsulated smoke pipe shall not pass through an attic, roof space, closet or similar concealed space, or through a floor, ceiling, wall or partition, or any combustible construction.**

**DO NOT USE ANY MAKESHIFT MATERIALS DURING INSTALLATION.**

1. Move the stove into position with the flue centered, mid-point between two joists to prevent having to cut them. Use a plumb bob to line up the centre.

2. Cut and frame an opening in the roof to provide a 2" clearance between the outside of the chimney and any combustible material.

**DO NOT FILL THIS SPACE WITH ANY TYPE OF MATERIAL.**

Nail headers between the joist for extra support. Firestop spacers must be placed on the bottom of each framed opening in any floor or ceiling that the chimney passes through.

3. Hold a plumb bob from the underside of the roof to determine where the opening in the roof should be. Cut and frame the roof opening to maintain proper 2" clearances.

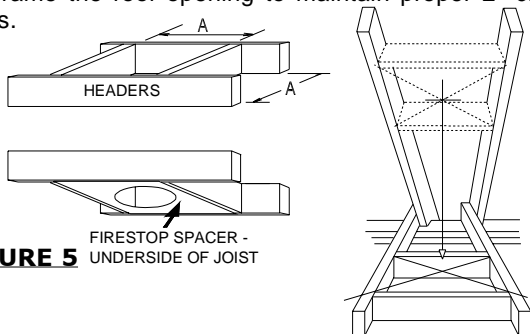

**FIGURE 5** FIRESTOP SPACER - UNDERSIDE OF JOIST

**ADDING CHIMNEY SECTIONS**

Add chimney sections, according to the manufacturer's installation instructions, securely, to the required height. The chimney must extend, at least, 3 feet above its point of contact with the roof and at least 2 feet higher than any wall, roof or building within 10 feet. **FIGURE 6.** If your chimney system is enclosed within the attic area, a rafter radiation shield is required.

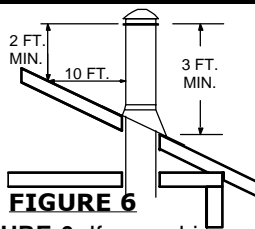

**FIGURE 6**

**PEDESTAL MODELS OUTSIDE AIR**

If possible connect the air intake at the pedestal's back or bottom to the outside with a 4 inch (100mm) diameter fresh air kit available at your Continental/Wolf Steel Ltd. dealer. Follow detailed instructions under "Mobile Home Outside Air".

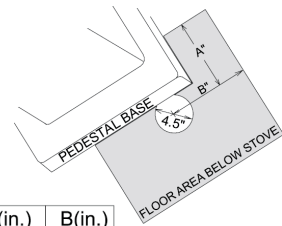

	A (in.)	B (in.)
1100	8 5/8"	9 3/4"
1400	11 1/8"	9 3/4"
1900	14 7/8"	9 3/4"

**FIGURE 7**

**WALL PASS-THROUGH**

If possible, design the installation so that the connector does not pass through a combustible wall. If during your installation you must pass through a combustible wall, check with your building inspector before you begin. Also check with the chimney connector manufacturer for any specific requirements.

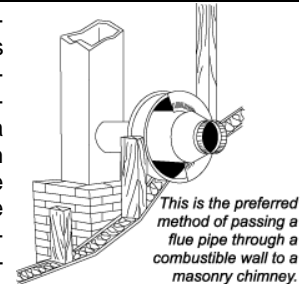

*This is the preferred method of passing a flue pipe through a combustible wall to a masonry chimney.*

Consult with your dealer regarding special connection components available for use for wall pass-throughs.

Use only parts that have been tested and listed for use in a wall pass-through.

**MOBILE HOME**

**PEDESTAL MODEL C1100 IS APPROVED FOR INSTALLATION IN MOBILE HOMES IN BOTH CANADA AND THE UNITED STATES.**

**PEDESTAL MODEL C1400 IS APPROVED FOR INSTALLATION IN MOBILE HOMES IN THE UNITED STATES ONLY.**

**WARNING: DO NOT INSTALL IN SLEEPING ROOM.**

**CAUTION: THE STRUCTURAL INTEGRITY OF THE MOBILE HOME FLOOR, WALL AND CEILING/ROOF MUST BE MAINTAINED.**

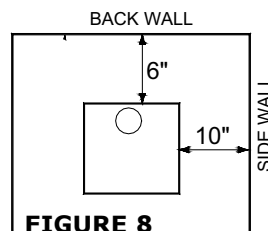

**FIGURE 8**

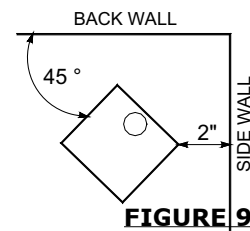

**FIGURE 9**

The pedestal base must be firmly bolted to the floor with 1/4 inch lag bolts. Minimum clearances to combustibles are as shown in **FIGURE 8.**

**VENTING**

Connect the stove to a chimney system using a listed double wall connector. Use a chimney system listed to ULC S629 in Canada or UL103HT in the U.S.A.

The chimney must be installed in accordance with the manufacturer's instructions. Use only specified components with no substitutions. The chimney and pipe must extend at least 8 feet above the stove and 3 feet above the highest point of the roof. Install a rain cap at the top which will not impede the smoke exhaust. The chimney must be supported at the ceiling or roof so that its weight does not rest on the stove.

It must be installed between ceiling joists, with radiation shield and roof flashing, so that the structural strength, insulation and waterproof qualities of the home are not lessened. Seal with silicone to maintain a vapour barrier at the chimney and outside air pipe penetrations.

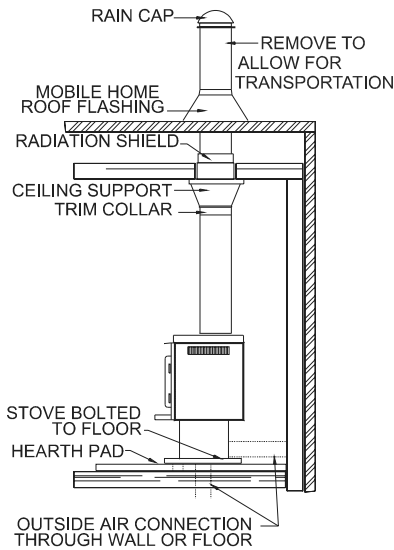

## OUTSIDE AIR

Connection from the stove's air intake to the outside is mandatory in mobile homes only, either through a hole in the wall to line up with the knockout in the pedestal back, or through a hole in the floor to line up with the hole in the pedestal base. Use a fresh air kit. Secure the 4 inch diameter aluminum liner by flaring the end once it is inserted through the 4-1/2 inch diameter hole in either the back or base of the pedestal. If the air intake is through the floor, the hole in the pedestal back must be covered with sheet metal to avoid cold air spillage into the room. A cover plate is available from your Wolf Steel Ltd. dealer. Avoid cutting away floor joists, wall studs, electrical wires or plumbing. Seal around the outside pipe with insulation to prevent drafts.

***If room air starvation occurs because the fresh air intake is blocked with ice, leaves, etc., or because the stove door was left open, or due to a strong exhaust fan operating etc., dangerous fumes and smoke from the operating stove could be drawn into the room.***

## FIREPLACE INSERT

Your EPI C1101 and C1401 insert firebox is the exact duplication of the clean-burning technology found in all Continental EPA certified freestanding stoves and in particular that of the EPA C1100 and C1400. External modifications have been made to allow its installation as a "functional fireplace insert" with a heat circulating blower system and a means of enclosing the solid fuel burning fireplace cavity for greater heating efficiency.

The EPI C1101 insert must be installed into a solid fuel burning fireplace that is at least 16 1/2 to 21 inches deep, 28 1/2 inches wide and 21 1/2 inches high with an approved lined chimney at least 15 feet high (4.6m).

Your EPI C1401 fireplace insert must be installed only into a solid fuel burning fireplace that is at least 14 inches deep 26 inches wide and 22 inches high with an approved lined chimney at least 15 feet high (4.6m). *This minimum recess can only be achieved if the opening height is sufficient enough to allow the connector to fit under the noncombustible facing.* The fireplace and chimney must be constructed in accordance with all national and local building code standards.

## HINT FOR INSTALLING PORCELAIN ENAMEL INSERTS:

**Ensure the base of the porcelain side panels are protected from rubbing against the hearth when sliding your insert into the masonry fire-place.**

## PRIOR TO INSTALLATION

Clean all ashes out of the inside of the fireplace. Make sure that the chimney and fireplace are free of cracks, loose mortar, creosote deposits, blockage or other signs of deterioration. If necessary, have any repair work done by a qualified professional before installing the insert.

Do **NOT** remove bricks or mortar from the fireplace. In case of an outside air inlet or ash dump, fill with fiberglass insulation. Adhere to minimum clearances as shown in **FIGURE 10**.

Do **NOT** place any combustible materials (furniture, firewood, etc.) within 48 inches in front or 36 inches at the side of the insert.

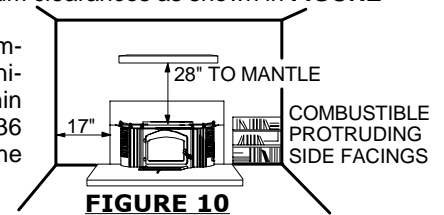

**FIGURE 10**

***Combustible material must not protrude more than 1" to the side of the insert or between the mantle and the top of the insert.***

## INSTALLATION INTO A MASONRY FIREPLACE

**1.** Remove the fireplace damper or fasten it permanently open.

**2.** Measure the throat of the fireplace and mark this shape on a piece of 24 gauge sheet metal (flue cover); cut a six-inch (150mm) hole to lie directly below the fireplace flue opening. Allow two inches of material for a flange on all sides and cut to these measurements. Bend down the flanges. If you have never done this before, it might be a good idea to make a cardboard pattern and test it first. Fasten this flue cover in position as high as possible with two masonry screws per side through the flanges into the fireplace. **FIGURE 11.**

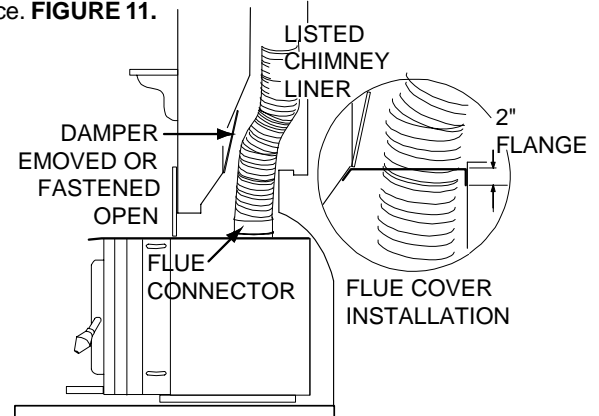

**FIGURE 11** MODEL C1401 Illustrated

***In Canada:*** Install a listed 6 inch diameter flexible stainless steel liner from the top of the chimney to the insert flue collar. Attach a stainless steel liner connector or elbow to the liner and insert onto the flue collar. Fasten with three screws. Secure the top of the liner to the chimney cap using a liner support and chimney flashing. Cap the top of the chimney liner assembly using an approved rain cap.

**In the United States:** While it is not required, it is recommended that a chimney liner be installed that is continuous from the insert to the top of the chimney, particularly when the insert is installed in a basement. For this type of connection, use the "In Canada" installation instructions above.

**In the United States, continued:**

If a continuous liner is not installed, a "direct flue connection" must be made. The direct flue connection requires a non-combustible connector that extends from the insert into the chimney flue liner and also that the installed flue cover be sealed below the entry point of the connector to prevent dilution of combustion products in the chimney flue with air from inside the house. Cap the top of the chimney using an approved rain cap.

**C1401 INSERT MODEL**

An optional low clearance flue connector is available to facilitate hook up into a tight fitting fireplace. Consult your local dealer for details.

The following installation requirements must be observed when installing solid fuel burning inserts into factory built fireplaces.

### INSTALLATION INTO A FACTORY BUILT FIREPLACE

1. The factory built fireplace must be listed per UL 127 or ULC S610.
2. Clearances to any combustible material surrounding this insert as identified in Figure 10 must be followed. These clearance requirements supersede any pre-existing facing material clearances listed for the factory built fireplace.
3. Installation must include a full height listed chimney liner meeting HT requirements (2100°F) per 1777 (U.S.) or ULC S635 (Canada). The liner must be securely attached to the insert flue collar and the chimney top.
4. Means must be provided to prevent room air passage to the chimney cavity of the fireplace. This may be accomplished by sealing the damper area around the chimney liner, or sealing the fireplace front.
5. The air flow within and around the fireplace shall not be altered by the installation of the insert (i.e. no louvres or cooling air inlet or outlet ports are blocked), unless specifically tested as such for each factory built fireplace manufacturer and model line. (Note - using a louvred face plate (surround) complies with this requirement)
6. Alteration of the fireplace in any manner is not permitted with the following exceptions;
  - a. external trim pieces which do not affect the operation of the fireplace may be removed providing they can be stored on or within the fireplace for reassembly if the insert is removed.
  - b. the chimney damper may be removed to install the chimney liner.
7. Circulating air chambers (i.e. in a steel fireplace liner or metal heat circulator) shall not be blocked.
8. Means must be provided for removal of the insert to clean the chimney flue.
9. Inserts that project in front of the fireplace must be supplied with appropriate support means.
10. A permanent metal warning label must be attached to the back of the fireplace stating that the fireplace must be restored to its original condition for safe use without the insert.

## OPTIONAL BLOWER

*Drywall dust will penetrate into the blower bearings, causing irreparable damage. Care must be taken to prevent drywall dust from coming into contact with the blower or its compartment. Any damage resulting from this condition is not covered by the warranty policy.*

Use of the blower increases the output of heat.

### STOVE MODELS

Provisions have been made on the stove to install an optional blower kit (EP62-1) that comes complete with a variable speed switch to turn the blower on and off, as well as adjusting the blower speed. An optional thermostatic sensor control kit, EP36, to thermally activate the blower is also available.

### LEG MODELS ONLY

*Note: if the optional blower (EP62-1) is installed, the blower guard (W320-0011) must be installed. This guard is available from your Continental dealer.*

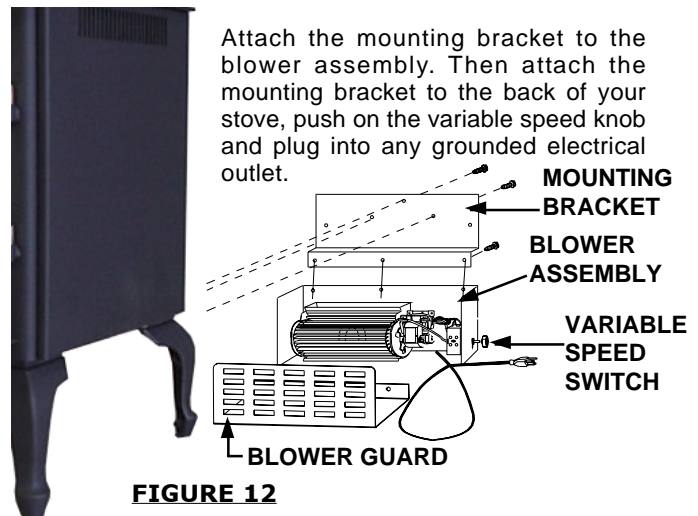

FIGURE 12

### INSERT MODELS

The C1401 insert comes equipped with two blowers, while the C1101 has one blower. These blowers are thermally activated. Depending on the intensity of the fire, the blowers will start 15-30 minutes after lighting. The heat sensor for the C1401 is located on the right hand side of the unit and the C1101 has a heat sensor located at the back on the blower access door. When first starting the fire, the sensor may be impeded by a large log or an unevenly burning fire, causing the blowers to cycle on and off. To control this, either build your fire up evenly or turn down the blowers until the right side of the firebox is hot.

**C1101 BLOWER SERVICE OR REPLACEMENT**

1. Turn off all electrical power to the insert. Remove the glass door and set aside in a safe place.

2. Remove the top right side bricks from inside the firebox, 4-#7's and 2-#2's. Then remove the rest of the side and back bricks from the right side of the C1101 insert. It is not necessary to remove the bottom bricks.

3. The access panel can be removed by taking out the 8 #10 self tapping screws. A 5/16" nut driver will be required to complete this job. Unplug wires from the thermal switch on the panel. See **FIGURE 13**.

4. Remove the securing wingnut from the blower mounting bracket, slide the bracket to the right and rotate the left side of the assembly out of the cavity to clear the blower motor. Disconnect the two wires from the blower motor. Remove the ground wire from the blower mounting bracket, then the assembly can be taken out of the rear cavity through the access door opening.

5. Remove the 3 screws that hold the blower to the mounting bracket. Service or replace the blower as required.

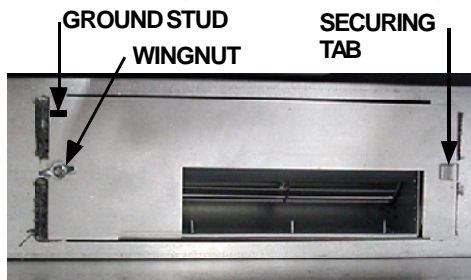
**FIGURE 14**

6. Reinstall the blower assembly making sure the blower bracket is seated under the securing tab. **FIGURE 14**. Reattach the wire connectors. **FIGURE 15**.

7. Replace the gasket on the access door. To replace the access panel, reverse Step 3.

8. Replace the bricks into the firebox. Reinstall the door.

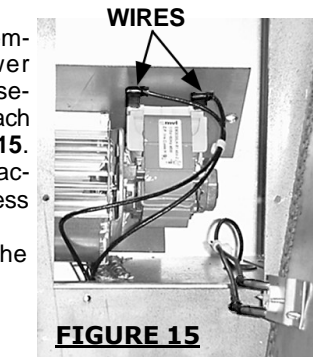
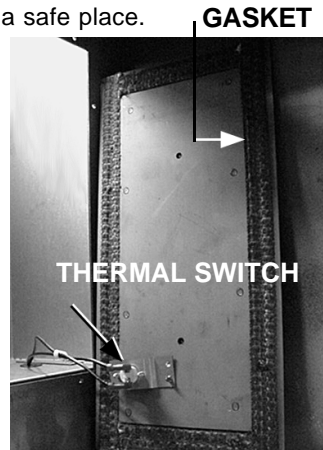
**FIGURE 15****FIGURE 13****C1401 BLOWER SERVICE OR REPLACEMENT**

1. Turn off all electrical power to the insert. Remove the glass door and set aside in a safe place.

2. Remove the two screws from the outer edge of the side panel(s).

3. Push the side panel toward the door and pull away from the insert, releasing the panel from the keyed slot.

4. Service or replace the blower(s) as required.

5. Re-install the side panel(s) by reversing the procedure.

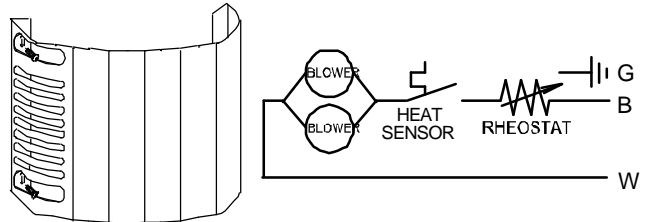
**FIGURE 16**

# FINISHING

SIZES		C1100/C1100C/ C1100L	C1101	C1400/C1400L	C1401	C1900
#1. 1-1/4" x 4"-1/2" x 9"	<b>BACK</b>	4-#1	4-#1	4-#1	4-#1	4-#7*
#2. 1-1/4" x 3" x 9"		2-#4	2-#4	2-#4	2-#4	2-#2
#3. 1-1/4" x 4-1/2" x 4-1/2"	<b>SIDES</b>	8-#1	8-#1	12-#1	12-#1	12-#7*
#4. 1-1/4" x 4-1/2" x 9"		2-#3	2-#3			2-#3 2-#4 (notched)
#5. 1-1/4" x 2-1/2" x 4-1/2"	<b>TOP</b>	2-#10	2-#10	2-#11	2-#11	2-#12
#6. 1-1/4" x 1-1/2" x 4-1/2"						2-#13
#7. 1-1/4" x 4-1/2" x 9" * (light weight)	<b>FLOOR</b>	3-#1	4-#1	5-#1	6-#1	7-#7*
#8. 1-1/4" x 2-1/4" x 9"		2-#2	2-#2	2-#2	2-#2	2-#2
#9. 1-1/4" x 2-1/4" x 6-1/8"		1-#5		1-#5		1-#5
#10. Fibre baffle - 9" x 1" x 12"	<b>FRONT</b>	1-#6		1-#6		1-#6
#11. Fibre baffle - 9" x 1" x 16 1/2"		2-#2	2-#2	2-#2	2-#2	2-#2
#12. Fibre baffle - 9" x 1" x 9 3/4"		1-#8	1-#8	1-#8	1-#8	1-#8
#13. Fibre baffle - 9" x 1" x 9 3/4"		1-#9	1-#9	1-#9	1-#9	1-#9

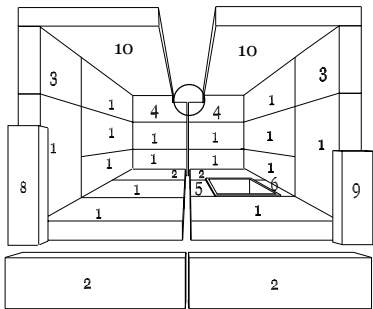

**MODEL C1100/C1100C/C1100L  
- FIGURE 17**

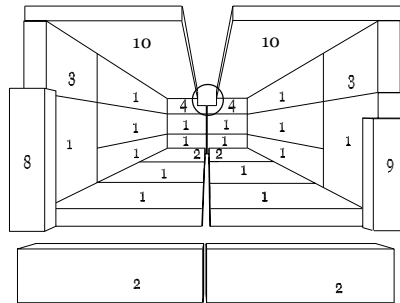

**MODEL C1101 - FIGURE 18**

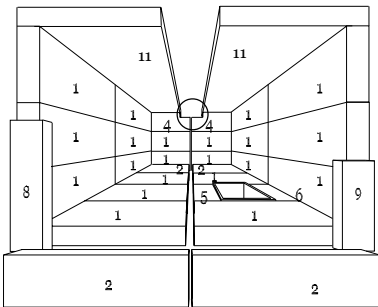

**MODEL C1400 / C1400L -  
FIGURE 19**

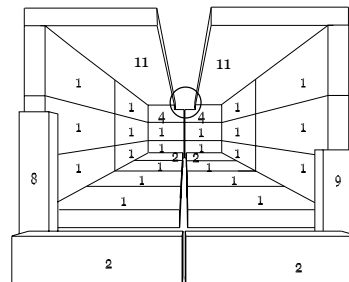

**MODEL C1401- FIGURE 20**

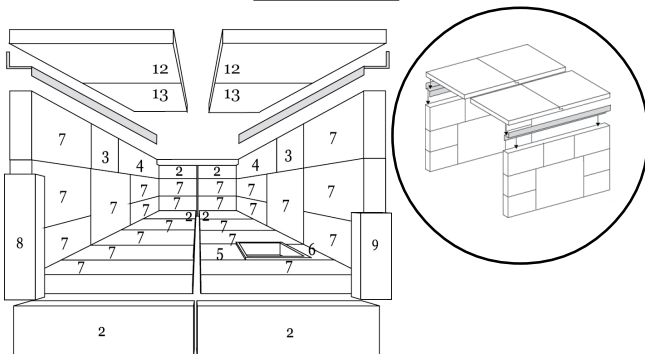

**MODEL C1900 - FIGURE 21**

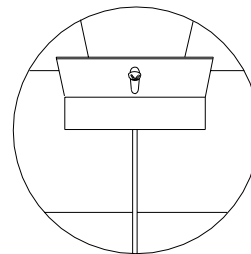

**AREA CIRCLED ON EACH FIGURE INDICATES THE  
BRICK RETAINER DETAIL**

**BRICK RETAINER DETAIL - TYPICAL**

## BRICKS AND BAFFLES INSTALLATION

With stove and chimney installation completed, move the bricks into place by working as illustrated for your unit on page 10.

**1.** Install two or three courses of brick on both sides of the unit. Install two courses on the back wall. Install the final course of bricks on the back wall. These bricks are held in place by a brick retainer. Before installing the bricks, loosen the screw holding the retainer and ensure that it has been moved forward. Insert the final two bricks behind the retainer and while still holding the bricks in place, slide the retainer snugly into place. Retighten the screw.

**2. C1900 only:**

*Place the stainless steel support onto the top row of the bricks as illustrated on page 10.*

*Pivot the 2 piece baffle up and onto the support, then slide them over and onto the flange of the manifold. Ensure that the overlaps are interlocked to close the gap. Push the baffles to the rear of the firebox. Repeat for the opposite side.*

Carefully pivot fibre baffle up onto the top of the side brick. Slide it over onto the flange of the manifold.

*Ensure that the top baffles are pushed all the way to the rear of the firebox, leaving a minimum of a 1 inch gap along the front. This will allow the flue gases to escape the firebox.*

**4.** Install the bottom bricks, working from the back of the unit.

**5.** Install the 2 bricks along the front.

## ORNAMENTAL TRIVET INSTALLATION

Insert the ornamental trivet into the space on the stove top.

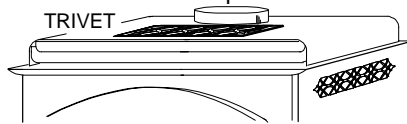

FIGURE 22

## DOOR AND HANDLE INSTALLATION

Hang the door using the hinge pins supplied. Twist the large wire handle over the end of the handle rod.

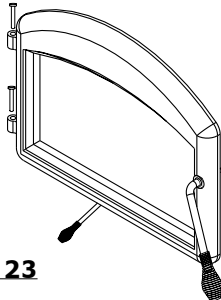

FIGURE 23

Twist the smaller wire handle over the end of the air damper rod below the door. Install ash pan pull handle using screws and washers. See FIGURE 26.

## PEDESTAL TRIM INSTALLATION

Ensure that the pedestal surfaces are clean and dry; peel the protective backing from the trim adhesive. Insert one end of the brass trim into one of the slots located in the pedestal and pressing firmly, proceed around to the other slot. Cut trim to size. Attach the rear knockout plate (located inside the ash pan for shipping purposes).

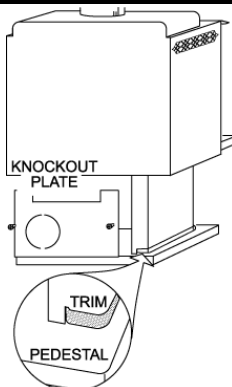
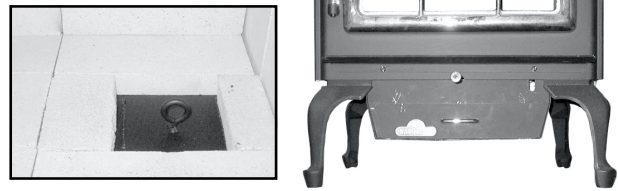

FIGURE 24

## OPTIONAL ASH DRAWER KIT

**Models C1100L / C1400L Only:** Provisions have been made on the stove to install an optional ash drawer kit. The EPAD-KT kit allows for convenient removal of excess ash. This kit can be purchased through your Continental Dealer.



## OPERATION

**CAUTION:** *Never use gasoline, gasoline-type lantern fuel, kerosene, charcoal lighter fluid, or similar liquids to start or 'freshen up' a fire in this heater. Keep all such liquids well away from the heater while it is in use.*

*Objects placed in front of the fireplace should be kept a minimum of 5" from the front face.*

Your Continental EPA listed product is a Hi-Tech unit, designed with the most advanced technology. The unit is extremely airtight. It has an exclusive direct outside air supply (optional kit), a safety feature designed to prevent spillage, and to keep your house free of carbon monoxide, in case of a downdrafting chimney or an internal negative pressure. The first fire(s) in your unit will be difficult to get going and keep going with little amount of heat being generated. This is a result of the moisture being driven out of the fire brick. Allow 30 to 40 hours of hot fires (temperatures in excess of 500°F - 600°F) before your unit will perform normally. During the break-in period (the first 2 or 3 fires) create only small, hot fires using kindling; this will allow the firebrick to cure. Do not be alarmed if small hairline cracks develop in the firebrick. This is a normal occurrence and does not pose a safety hazard. The paint may also smell a little for the first few fires as it cures and you may wish to open a door or window to alleviate the smell.

To start, a brisk fire is required. Place loosely crumpled paper on the floor of the stove and cover with dry kindling. Open the draft control fully by pulling the lever forward. Light the paper and leave the door slightly ajar (one inch) until all kindling is burning. To maintain a brisk fire, a hot coal bed must be established and maintained.

Slowly add larger wood (2x4 size pieces). Lay the pieces lengthwise from side to side in the hot coal bed with a shallow trench between, so that the primary air can flow directly into this trench and ignite the fuel above. When the fire seems to be at its peak, medium sized logs may be added. Once these logs have caught fire, carefully close the door. (Closing the door too quickly after refueling will reduce the firebox temperature and result in an unsatisfactory burn.) Remember it is more efficient to burn medium sized wood, briskly, and refuel frequently than to load the fireplace with large logs that result in a smouldering, inefficient fire and dirty glass.

As soon as the door is closed, you will observe a change in the flame pattern. The flames will get smaller and lazier because less oxygen is getting into the combustion chamber. The flames, however, are more efficient. The flames will remain lazy but become larger again as soon as the firebricks have been heated thoroughly and the chimney becomes heated and provides a good draft. At this point, the roaring fire that you see when the door is opened is wastefully drawing heated room air up the chimney -- certainly not desirable. Always operate with the door fully closed once the medium sized logs have caught fire.

You can now add larger pieces of wood and operate the stove normally. Once the stove/insert is entirely hot, it will burn very efficiently with little smoke from the chimney. There will be a bed of orange coals in the firebox and secondary flames flickering just below the top firebrick. You can safely fill the firebox with wood to the top of the door and will get best burns if you keep the stove pipe temperatures between 250 degrees Fahrenheit (120 degrees Celsius) and 450 degrees Fahrenheit (270 degrees Celsius). A surface thermometer will help regulate this.

***Without a stove thermometer, you are working blindly and have no idea of how the stove is operating! A stove thermometer offers a guide to performance.***

Can't get the fire going? Use more kindling and paper. Assuming the chimney and vent are sized correctly and there is sufficient combustion air, the lack of sufficiently dry quantities of small kindling is the problem. Thumb size is a good gauge for small kindling diameter.

Can't get heat out of the unit? One of two things may have happened. The stove/insert door may have been closed prematurely and the unit itself has not reached optimum temperature. Reopen the door and/or draft control to re-establish a brisk fire. The other problem may have been wet wood. The typical symptom is sizzling wood and moisture being driven from the wood.

### ACHIEVING PROPER DRAFT

Draft is the force which moves air from the firebox up through the chimney. The amount of draft in your chimney depends on the length and diameter of chimney, local geography, nearby obstructions and other factors. Adjusting the draft control regulates the temperature.

The draft can be adjusted from a low burn rate with the handle in fully, to a fast burn rate with the handle fully out. Inadequate draft may cause back-puffing into the room through the stove/insert and chimney connector points and may cause plugging of the chimney. Too much draft may cause an excessive temperature in the stove, glowing red stove parts or chimney connectors or an uncontrollable burn which can lead to a chimney fire or permanent damage to the unit.

Do not operate your stove/insert for longer than 30 minutes with the draft control on "HIGH" (fully open).

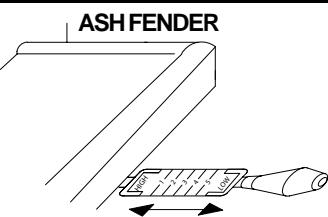

FIGURE 25

**\* NOTE: C1100C and optional EPA Leg Models ash pans are not equipped with a cover or rear folding handle.**

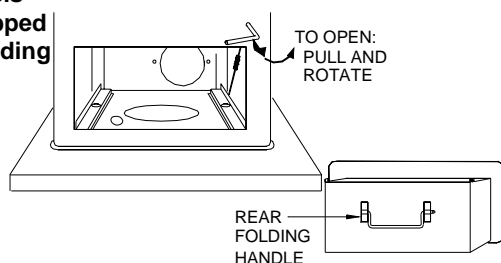

FIGURE 26

W415-0361/09.21.04

### FIRE EXTINGUISHERS / SMOKE DETECTORS

All homes with a solid fuel burning fireplace should have at least one fire extinguisher in a central location known to all, and at least one smoke detector in the room containing the fireplace. If it sounds an alarm, correct the cause but do not deactivate or relocate the smoke detector.

### FUEL LOADING AND BURN CYCLE

***When loading the stove, ensure that the two upper courses of firebrick are not lifted up and off their ledge.***

For maximum efficiency, when the stove is thoroughly hot, load it fully to the top of the door opening and burn at a medium low setting. Maximum heat for minimum fuel (optimum burn) occurs when the stove top temperature beneath the trivet is between 500°F (260°C) and 600°F (315°C). The bricks will be nearly all white and the glass mostly clear. The whiteness of the bricks and the cleanness of the glass are good indicators of your operating efficiency. Not enough heat is produced when only one or two pieces of wood are burned or the wood may not burn completely. A minimum of three pieces are needed to encase a bed of coals that sustains the fire.

Loosely stacked wood burns quicker than a tightly packed load. Wood burns in cycles rather than giving a steady output of heat. It is best to plan these cycles around your household routine so that only enough coals are left to start the next load. In the evening, load your stove, at least, a half-hour before bed to ensure a good fire, hot enough to close the draft control for an overnight burn. Burn only dry seasoned wood.

It produces more heat and less soot or creosote. Do not burn ocean beach wood. Its salt content can produce a metal eating acid. When refueling open the door slowly to prevent smoke spillage. Use a pair of long gloves (barbecue gloves) when feeding the fire. Because these stoves burn at the front, they are clean and efficient, but they are also very hot and gloves are useful. Keep a small steel shovel nearby to use as a poker and to remove ashes. Do not store the wood within 3 feet (1m) of the stove.

### FLASH FIRE

A flash fire is a small fire burned quickly when you don't need much heat. After your kindling has "caught", load at least 3 pieces of wood, stacked loosely. Burn with the draft control fully open or closed only slightly.

### EXTENDED FIRE

Load your larger pieces of wood compactly, packed close enough to prevent the flames from penetrating it completely. After approximately 30 minutes, depending on the size of the load, close the draft control completely making sure that the fire is not extinguished.

#### **DO NOT OVERFIRE THE STOVE!**

Overfiring can occur by:

- burning large amounts of smaller wood pieces such as furniture scraps, skids or treated wood;
- vigorously burning large loads of wood with the draft control on "HIGH" (fully open) for long periods of time (one or two hours).

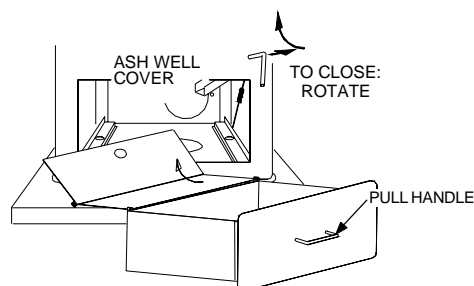

## SMOKING

A properly installed Continental unit should not smoke. If yours does, check the following: Has the chimney had time to get hot? Is the smoke passage blocked anywhere in the stove, chimney connector or chimney? Is the room too airtight and the air intake not connected to the outside? Try with a window partly open. Is the smoke flow impeded by too long a horizontal pipe or too many bends? Is it a weak draft perhaps caused by a leaky chimney, a cold outside chimney, too large a diameter of a chimney, too short a chimney, or a chimney too close to trees or a higher roof? Has a direct flue connection been used rather than a chimney liner continuous from cap to fireplace flue collar.

## ASH REMOVAL PROCEDURES

Allow the ashes in your firebox to accumulate to a depth of two or three inches; they tend to burn themselves up. When the fire has burned down and cooled, remove any excess ashes but leave an ash bed approximately 1 inch deep on the firebox bottom to help maintain a hot charcoal bed.

## PEDESTAL UNITS WITH ASH PAN

To use your ash pan, pull the ash dump handle forward (**FIGURE 26**), rotate approximately 90° counterclockwise to the open position. Rake the excess ashes into the ash pan. Close the ash well.

**NEVER OPERATE YOUR STOVE WITH THE ASH WELL IN AN OPEN POSITION.**

This creates a fire hazard that may result in a house/chimney fire, internal damage to the stove or discoloration to the gold plated door (plated finishes are not covered by the warranty). To ensure that the ash well is fully closed, allow the door to snap shut, dislodging anything that may be stuck at the opening. Flip the cover up onto the ash pan when transporting the ashes to a closed container with a tight fitting lid for storage. Carry the ash pan using the front and back handles.

\* **FIGURE 26.**

## UNITS WITHOUT ASH PAN

Since these models have no ash pan, shovel some ashes out through the door into a metal container with a tight fitting lid. Leave an ash bed approximately 1 inch deep on the firebox bottom to help maintain a hot charcoal bed. Keep the closed container on a noncombustible floor or ground, well away from all combustible materials. The ashes should be retained in the closed container until all cinders have thoroughly cooled. Cold wood ashes can be used on the garden or in the compost.

**FIGURE 27**

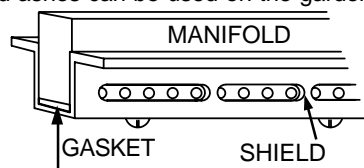

## LEG UNITS WITH ASH PAN

1. To remove the ashes, clear the ash away from the ash plug.
2. Remove the ash plug. **It is recommended to use a poker.**
3. Rake the excess ash into the ash drawer.  
**Do not overfill the ash drawer. Ash should not accumulate higher than the sides of the drawer.**
4. Before removing the drawer, ensure that the area around the ash opening is clean. Tap the ash from the chute into the drawer, then place the ash plug back over opening.  
**Never operate your stove with the ash plug removed.**

## MAINTENANCE

Check your chimney and chimney connector for creosote and soot buildup weekly until a safe frequency for cleaning is established. If accumulation is excessive, disconnect the stove and clean both the chimney and the stove. You may want to call a professional chimney sweep to clean them. Both have to be cleaned at least once a year or as often as necessary. Remove fibre baffles and clean above them once a year. Replace any broken bricks.

## CREOSOTE FORMATION AND REMOVAL

When wood is burned slowly, it produces tar and other organic vapours which combine with expelled moisture to form creosote. These vapours condense in the relatively cooler chimney flue of a slow burning fire and when ignited, make an extremely hot fire. So, the smoke pipe and chimney should be inspected monthly during the heating season to determine if a buildup has occurred. If creosote has accumulated it should be removed to reduce the risk of a chimney fire.

## RUNAWAY OR CHIMNEY FIRE

Runaway fires can be the result of **three** major factors:

1. Using incorrect fuel, or small fuel pieces which wood normally be used as kindling.
2. Leaving the door ajar too long and creating extreme temperatures as the air rushes in the open door.
3. Burning your stove with the ash dump door open.

### SOLUTIONS:

1. Do not burn treated or processed wood, coal, charcoal, coloured paper or cardboard.
2. Be careful not to over-fire the unit by leaving the door open too long after initial start-up. A thermometer on the chimney connector and/or stove top helps.
3. Always operate the stove with the ash well in a closed position.

## WHAT TO DO IF A RUNAWAY OR CHIMNEY FIRE STARTS

1. Close the door and draft fully.
2. Call local fire department.
3. Examine flue-pipes, chimney, attic, and roof of the house, to see if any part has become hot enough to catch fire. If necessary spray with a fire extinguisher or water from a garden hose.
4. Do not operate the stove again until you are certain the chimney and its lining have not been damaged.

## GASKET REPLACEMENT

At the end of each burning season inspect the shield and gasket below the manifold for warping or deterioration. Replace if necessary. Both are held to the manifold with machine screws. The shield and the 1/8" fibre cloth gasket are available from your Wolf Steel Ltd. dealer. See **FIGURE 27**. At this time also check that the door gasket is not worn or loose. Replace with 3/8" high density fiberglass rope if necessary.



# REPLACEMENTS

Contact your dealer for questions concerning prices and availability of replacement parts. Normally all parts can be ordered through your Continental dealer or distributor. When ordering replacement parts always give the following information:

1. MODEL & SERIAL NUMBER OF FIREPLACE
2. INSTALLATION DATE OF FIREPLACE
3. PART NUMBER
4. DESCRIPTION OF PART
5. FINISH

**FOR WARRANTY REPLACEMENT PARTS, A PHOTOCOPY OF THE ORIGINAL INVOICE WILL BE REQUIRED TO HONOUR THE CLAIM.**

**\* IDENTIFIES ITEMS WHICH ARE NOT ILLUSTRATED. FOR FURTHER INFORMATION, CONTACT YOUR CONTINENTAL DEALER.**

## REPLACEMENT PARTS

#	PART NO.	DESCRIPTION
1	W325-0002	SPRING HANDLE - SMALL
1	W325-0007	SPRING HANDLE - LARGE
2*	W090-0001	BRICK - # 1
3*	W090-0002	BRICK - # 2
4*	W090-0003	BRICK - # 3 - MODELS C1100, C1100C, C1100L, C1101, C1900
5*	W090-0004	BRICK - # 4 LEFT
6*	W090-0005	BRICK - # 4 RIGHT
7*	W090-0016	BRICK - # 5 - MODELS C1100, C1100C, C1400, C1900
8*	W090-0017	BRICK - # 6 - MODELS C1100, C1100C, C1400, C1900
9*	W090-0015	BRICK - # 7
10*	W090-0018	BRICK - # 8
11*	W090-0019	BRICK - # 9
12*	W018-0077	# 10 FIBRE BAFFLE - MODEL C1100, C1100C, C1100L, C1101
13*	W018-0078	# 11 FIBRE BAFFLE - MODEL C1400, C1400L, C1401
14	W018-0092	# 12 FIBRE BAFFLE - MODEL C1900
15	W018-0093	# 13 FIBRE BAFFLE - MODEL C1900
16	W655-0209	BAFFLE SUPPORT BRACKET - MODEL C1900
17	W715-0073	ASH FENDER TRIM c/w CORNER BRACKETS
18*	W160-0014	SPRING CLIP FOR ASH FENDER
19	W010-0347	AIRWASH GASKET & SHIELD
20*	W570-0007	SCREWS for MANIFOLD & SHIELD
21	GZ551	REPLACEMENT FAN
22*	W200-0077	BLACK TRIVET - MODEL C1100
23*	EP-11MS	MANIFOLD GASKET & SHIELD - MODELS C1100, C1100C, C1100L, C1101
24*	W580-0001	COMPLETE BRICK SET - MODEL C1100, C1100C
24*	W580-0002	COMPLETE BRICK SET - MODEL C1400
24*	W580-0005	COMPLETE BRICK SET - MODELS C1401, C1400L
24*	W580-0003	COMPLETE BRICK SET - MODEL C1900
24*	W580-0006	COMPLETE BRICK SET - MODELS C1101, C1100L
25*	EP-14MS	MANIFOLD GASKET & SHIELD - MODELS C1400, C1401, C1400L
26*	W690-0002	HEAT SENSOR - MODELS C1101, C1401
27*	GS-330K	BLACK TRIVET - MODELS C1400 & C1900
28*	EP-19MS	MANIFOLD GASKET & SHIELD - MODEL C1900
29*	CL28	BLACK CANOPY LOUVRES - MODELS C1100, C1400, C1900
29*	CL28G	GOLD PLATED CANOPY LOUVRES - MODELS C1100, C1400, C1900
30	W010-0349	PEDESTAL TRIM - MODELS C1100, C1400, C1900
31	KB-35	VARIABLE SPEED CONTROL c/w KNOB - MODELS C1100, C1100C, C1100L, C1400, C1401, C1400L, C1900
32*	KB-36	VARIABLE SPEED CONTROL c/w KNOB - MODEL C1101
33	W010-0243	ASH PAN (NO FRONT PLATE) - MODELS C1100, C1400, C1900
34	W325-0011	ASH PAN HANDLE - MODELS C1100, C1400, C1900
35	W510-0001	5/16" PLUG - MODELS C1100L, C1400L, C1401
36	W135-0143**	CAST TOP
37	W135-0144**	CAST SIDES
38	W135-0145**	CAST ASHLIP
39	W135-0146**	CAST LEG
40	W135-0147**	CAST DOOR

\*\*FOR AVAILABLE PORCELAIN COLOURS,  
ADD THESE LETTERS TO THE BASE PART NUMBER:  
GREEN - F  
BROWN - N  
BLACK - K

## ACCESSORIES

#	PART NO.	DESCRIPTION
41	H222G	GOLD PLATED DOOR
41	H222	BLACK DOOR
41	H222SS	BRUSHED STAINLESS STEEL DOOR - STANDARD ARCH
42	H222W	BLACK DOOR - EARLY AMERICAN
42	H222GW	GOLD DOOR - EARLY AMERICAN
42	H222SSW	BRUSHED STAINLESS STEEL DOOR - EARLY AMERICAN
43	W010-1071	DOOR GLASS w/ GASKET
44*	W020-0043	DOOR GASKET
45*	W020-0050	GLASS GASKET
46	GS200-G	ORNAMENTAL TRIVET - GOLD PLATED - MODEL C1100
46	GS-330G	GOLD PLATED TRIVET - MODELS C1400, C1900
46	GS-530G	ORNAMENTAL TRIVET - GOLD PLATED - MODELS C1400, C1900
47	EP62-1	VARIABLE SPEED BLOWER - MODELS C1100, C1100L, C1400, C1400L, C1900
48*	W500-0064	FRESH AIR COVER PLATE - MODELS C1100, C1400, C1900
49*	111KT	OUTSIDE AIR KIT - MODELS C1100, C1400, C1900
50*	W470-0002	ENAMEL TOUCH UP & BRUSH (SPECIFY COLOUR) - MODELS C1100, C1400, C1401, C1900
51	EPA335KT	LOW CLEARANCE FLUE CONNECTOR - MODEL C1401
52	EPI-RK	SOLID BRASS RAILING KIT - MODEL C1401
52	EPA-RK	SOLID BRASS RAILING KIT - MODELS C1100L, C1400L
53	AK-1	ADAPTER KIT FOR CISK - MODEL C1101
54	AK-2	ADAPTER KIT FOR CISK-A - MODEL C1401
55	CISK**	CAST IRON SURROUND KIT, PAINTED BLACK
55	CISK**A	CAST IRON SURROUND KIT, ENAMEL PORCELAIN
56	EI-900K10	10" FLASHING KIT c/w BULL NOSE TRIM - MODEL C1101
57*	EPLK	AIR CIRCULATION CHAMBER LOUVRES (BLACK) - MODELS C1100L, C1400L
57*	EPLG	AIR CIRCULATION CHAMBER LOUVRES (GOLD) - MODELS C1100L, C1400L
57*	EPLSS	AIR CIRCULATION CHAMBER LOUVRES (BRUSHED STAINLESS STEEL) - MODELS C1100L, C1400L
58	W320-0011	BLOWER GUARD - MODELS C1100L, C1400L
59*	EP36	THERMOSTATIC SENSOR CONTROL KIT - MODELS C1100, C1100L, C1400, C1400L, C1900
60	200K	TRADITIONAL STEEL LEGS (BLACK) - MODEL C1100L, C1400L
61	202CK	ORNAMENTAL CAST IRON LEGS - MODEL C1100L, C1400L
61	202CG	ORNAMENTAL CAST IRON LEGS (GOLD PLATED) - MODEL C1100L, C1400L
61	202CSS	ORNAMENTAL CAST IRON LEGS (BRUSHED STAINLESS STEEL) - MODEL C1100L, C1400L
62	EPAD-KT	ASH DRAWER KIT - LEG MODELS

\*\*FOR AVAILABLE PORCELAIN COLOURS,  
ADD THESE LETTERS TO THE BASE PART NUMBER:  
GREEN - F  
BROWN - N  
BLACK - K  
BLUE - B

